

MIAMI UNIVERSITY
BOARD OF TRUSTEES
Oxford Campus
Minutes of the Board of Trustees Meeting
Philip R. Shriver Center, Multi-Purpose Room
Friday, February 7, 2014

The Secretary to the Board confirms that as specified in the Regulations of the Board of Trustees of Miami University, and in compliance with Section 121.22 of the Ohio Revised Code, due notice had been given prior to the holding of this meeting of the Board of Trustees.

The meeting was called to order at 9:00 a.m. in the Phillip R. Shriver Multi-Purpose Room, on the Oxford Campus with the Board Chair, Ms. Sharon Mitchell, presiding. The Secretary of the Board, Mr. Dennis Lieberman called the roll and reported nine voting members present; constituting a quorum for the purpose of transacting business. In addition to the Board members; President Hodge, Vice Presidents Creamer, Gempesaw, Herbert and Natale were present; as was Dr. Jayne Brownell, incoming Vice President for Student Affairs, along with Robin Parker, General Counsel; Deedie Dowdle, Associate Vice President for Communications and Marketing; and Ted Pickerill Secretary to the Board of Trustees. Members of the faculty, staff, student body and community were also in attendance.

Present: John Altman (National Trustee) C. Michael Armstrong (National Trustee) Jagdish K. Bhati Graham Bowling (Student Trustee) David H. Budig Donald L. Crain C. Michael Gooden (National Trustee) Sue J. Henry (National Trustee)	Terry Hershey (National Trustee) Denise A. Lieberman Sharon J. Mitchell Mark E. Ridenour Robert W. Shroder Stephen P. Wilson Harry T. Wilks
--	---

Absent: Arianne Wilt (Student Trustee)

Executive Session

Mr. Shroder moved, Mr. Budig seconded, and by unanimous roll call vote the Board convened to Executive Session to discuss personnel matters and pending litigation, as provided by the Open Meetings Act, Ohio Revised Code Section 121.22. Following adjournment of the Executive Session, the Board convened into the Public Study Session.

Public Study Session

Love and Honor Campaign Update

Vice President for Advancement Thomas Herbert updated the Board on the completion and success of the for Love and Honor campaign.

Mr. Herbert outlined the impact of the campaign, which included facilities, such as the Armstrong Student Center, and the Farmer School of Business Building, scholarships, and faculty support. \$132 million was dedicated to scholarships, enabling the creation of nearly 600 new scholarships.

Mr. Herbert also outlined priorities for the future, which again included scholarships, and he described the Scholarship Match program for the Board.

Mr. Herbert did not, however, reveal the final, grand total for the Campaign; this announcement was being reserved for the next evening during the Gala celebration.

Materials from this presentation are provided as Attachment A.

Armstrong Student Center's Great Miami Seal

Mr. Robert Keller, University Architect Emeritus made a presentation on the 3-dimensional Great Miami Seal in the Armstrong Student Center's rotunda. His presentation was accompanied by a slide show of photos chronicling the process. The photos are included as Attachment B.

Mr. Keller explained that nearly every element of the Seal has a connection to Miami history and the student experience.

The rope was provided by Delta Upsilon fraternity, and was used in Greek Week tug-of-war completions for many years. The ropes were woven together by Nathan Foley, a master's student in sculpture.

Bricks for the Seal's inner ring were recovered from construction projects at Miami's oldest buildings, Stoddard and Elliot Halls, and other buildings on campus.

The globe was recovered from the observatory of Culler Hall. Originally a celestial globe, master's student Ben Mark crafted the continents from metal which were added to the globe's surface.

The contents of the book are the writings of Miami students. The book is open to the winning essay, written by Amanda Hancock. The book also contains twelve pen and ink sketches drawn by sisters Madelyn and Sophia Delgado. The paper for the pages of the book was produced by students in the Department of

Chemical, Paper, and Biomedical Engineering.

The telescope is the spotting scope for a larger telescope and was recovered from the Physics Department. Physics faculty designed, and staff from the instrumentation laboratory in Hughes Hall, created the base.

The bronze star and comets were created by alumni during CraftSummer, under the direction of Professor Emeritus Jim Kelly.

The night sky in the background of the Seal is a depiction of the Ohio sky on February 17, 1809 – the day Miami University was chartered.

At the conclusion of the presentation Mr. Armstrong commented on the beauty of the Seal, and predicted it will be Loved and Honored for many generations. Mr. Keller was then thanked by the Board and received a round of applause.

Materials from this presentation are included as Attachment B.

Public Business Session

Approval of the Minutes of the December 6, 2013 Meeting

Mr. Ridenour moved, Mr. Wilson seconded, and by voice vote the minutes of the December 6, 2013 Board of Trustees meeting were unanimously approved, with nine Trustees voting in favor and none opposed.

Consent Calendar

Mr. Ridenour moved, Mr. Budig seconded, and by voice vote the Resolution presented on the Consent Calendar (R2014-18) was unanimously approved, with nine Trustees voting in favor and none opposed.

Designation of Emerita/Emeritus

RESOLUTION R2014-18

BE IT RESOLVED: that the Board of Trustees hereby approves the following for the rank of Professor Emerita effective on the formal date of retirement:

Kathy M. McMahon-Klosterman
Educational Psychology

Emily S. Murphree
Statistics

BE IT FURTHER RESOLVED: that the Board of Trustees hereby approves the following for the rank of Professor Emeritus effective on the formal date of retirement:

Mark R. Boardman
Geology and Environmental Earth Science

Mark E. de Saint Rat
Mathematics

Osama M. Ettouney
Mechanical & Manufacturing Engineering

Thomas W. Kopp
Teacher Education

Eugene W. Metcalf
American Studies Program

Michael J. Pechan
Physics

Robert L. Schaefer
Statistics

Mark A. Smith
Mathematics

BE IT FURTHER RESOLVED: that the Board of Trustees hereby approves the following for the rank of Administrator Emerita effective on the formal date of retirement:

Linda J. Dixon
Student Affairs, Rinella Learning Center

Gail M. King
Housing, Dining, Recreation and Business Services

Cathleen M. Pierce
Housing, Dining, Recreation and Business Services

BE IT FURTHER RESOLVED: that the Board of Trustees hereby approves the following for the rank of Administrator Emeritus effective on the formal date of retirement:

Duchan Besedick
Environment Safety and Risk Management

Comments by the Chair

Good morning and welcome to the first meeting of 2014. This is a very exciting time for Miami, and a great source of that excitement is the Armstrong Student Center which will be dedicated later today. I invite everyone to join us for this historic event.

I'd like to begin by welcoming Miami's newest leaders; Dr. Jayne Brownell, who will become our next Vice President for Student Affairs, Dr. Matt Myers, who will soon become the Dean of the Farmer School of Business, and Jerome Conley, Dean and University Librarian.

On behalf of the Board, I'd like to welcome you all.

In December we shared the excitement of 1,049 graduates and their families during the Fall commencement ceremony, which was highlighted by the remarks of Dr. Timothy Greenlee, Professor of Marketing and the 2013 Effective Educator.

In January, we experienced Miami's first ever Winter Term, which saw over 3,500 students enroll in classes on campus, online, and abroad.

For some, this was an opportunity to complete a requirement needed for graduation. Eighty students were able to graduate as a result of coursework they completed during Winter Term. For others – it was an opportunity for international study or to broaden their horizons by taking a course they might not otherwise have been able to take.

Students went to Australia to work with Suncorp; others traveled to Singapore, Hong Kong, Shanghai and Beijing to learn about foreign financial markets, and still others traveled to London, Cambodia, Cuba, Colombia, Nicaragua and Ghana - to name just some of the locations where they studied.

Students also experienced media, journalism and film firsthand through the "Inside Hollywood" workshop in California and the first ever "NYC Media" workshop in New York City.

Engineering students worked together to build a skiing robot in Canada, while others traveled to Zambia to do research in understanding and managing groundwater resources and water quality.

Overall, the Winter Term has been quite a success!

Later today, when you visit the Armstrong Student Center, you may want to check out the Sustainability information near the west entrance which discusses the building's Green attributes. This is one of the best descriptions of Sustainability I have ever seen. Miami is committed to this building receiving a 'Silver' LEED certification by the U.S. Green Building Council's Leadership in Energy and Environmental Design. Just a few of the Armstrong Center's green attributes include:

- Use of recycled construction materials
- Extensive use of natural lighting
- Smart heating and cooling systems, and
- Compostable food service packaging.

Another truly unique aspect on the Armstrong Student Center is that it is totally student led. The Center's 17-member governing board, comprised entirely of students, works with Armstrong Center staff to set policy at the Center. Over the past year, these students have served on 12 planning teams along with university employees to focus on issues ranging from the type of technology in the building to room reservation policies. Earlier today we had the pleasure of meeting these student leaders. Their effort, vision and achievement make the Armstrong Student Center an amazing experience.

The enriching experience of a Miami education is evidenced in the results of the most recent survey of graduates which shows that more than 91 percent of Miami University graduates were employed or in graduate school the year after graduation. Our Marketing organization has found a fun and engaging way to summarize this outstanding result – We can now claim – Miami grads land where they planned!

Something which makes these survey results even more impressive is that Miami achieves these results through extreme efficiency - spending relatively less than nearly every other university in the nation. This efficiency was recognized by U.S. News and World Report - which ranked Miami second in the nation in efficiently achieving educational quality. These results stand out and highlight the value of Miami as our nation debates the cost of a college education.

The U.S. News results are echoed by Kiplinger, which recognized Miami's “high four-year graduation rate, low average student debt at graduation, abundant financial aid, low sticker price and overall great value,” to place it on the top 100 “Best Values” list for 2014. The Kiplinger list features public colleges that deliver a quality education at an affordable price. Miami has placed in the 100 Best Values list every year since Kiplinger’s began publishing the rankings in 1998.

One significant reason for the success of our alumni is Miami's dedicated faculty and staff. Recently four faculty received the University Distinguished Teaching Award for their excellence.

The award is conferred upon those faculty members whose achievements unequivocally merit recognition for excellence in teaching. Up to four awards are given annually with up to one award for each of the four levels of Miami University faculty. This year's awardees include:

- Professor - R. Hays Cummins, Western program and geography
- Associate Professor - James Moller, mechanical and manufacturing engineering
- Assistant professor - Martha . Casta eda, teacher education, and
- Lecturer - Joseph Bates, English

We congratulate these outstanding teachers, and thank them for their contributions.

Finally – this week we are celebrating the successful completion of the Love and Honor Campaign. As we celebrate this milestone I would like to take the opportunity to thank President David Hodge and Valerie Hodge for the amazing role they have played in this campaign in achieving our goal, and in shaping the Armstrong Student Center. Without their tenacity and commitment to the campaign and the Armstrong Student Center we would not be where we are today.

These are indeed exciting times as Miami embraces our tradition of an unparalleled student experience; a student experience which will become even more fulfilling as we dedicate the Armstrong Student Center later today.

I hope you can all join us.

Reports, Ordinances and Resolutions

President's Report

Thank you. It's my pleasure to be here today. What a fantastic two days we have ahead of us. Of course today it's about the Armstrong Student Center and I want to congratulate Bob for his extraordinary presentation which is based on extraordinary work. I have had the privilege over the last few years of hearing Bob go through this process step-by-step and it's fantastic. The creativity that's there is off the charts as it is with the building. When we think about the Armstrong Student Center there are three attributes that come to mind.

First, it is just flat-out, stunningly beautiful. We scored big time - the architects were nothing short of brilliant in the way that they have put these spaces together in a manner that avoided any sense of ostentation and yet has a quality about it that we all admire hugely.

Secondly, it's an efficient building. Sharon just shared with us a lot of information about the sustainability, and that certainly was one of our core features from the beginning and it reflects our commitment as a University to sustainability. But it's also a building that represents the kind of efficiency that earned us the #2 ranking in the Nation for being the most efficient University for producing high quality results. This was again a feature of Bob's thinking. It starts with Bob. The world seems to revolve around Bob today - as it should. But when our initial planning was to knock down the three buildings in the middle of campus and to construct an entirely new building, it came in as entirely too expensive and so we had to drop that idea. Bob was asked to come back with a possible plan B. I was thinking a smaller building, a different site, all sorts of alternatives that we might go to, and after he sandbagged me with the first seven options, we got to the eighth option which was when he said "I'm looking at the way these three buildings are located relative to each other." And he starts scratching his head, and said "it just occurred to me that if we could bring those in, maybe we could save some money." Well, we're saving about 40% of the cost of what it would have been to have

knocked those buildings down and to build new. 40%'s a big number, but of course at the end it's not that we've saved all that money, but we actually ended up with a far superior outcome, unique, I believe is the world that is used.

And finally, and perhaps most importantly of all, it is a building that works. It's a building that was designed 100% with the idea that this would be a building for the students and the planning that went into it over the years about; what do students need?, what do they want?, how is this going to work?, was truly, truly exceptional. From the way the student organizations are going to be able to interact, from the study rooms, to the Shade Family Room, to all the glass walls (that the architects insisted on putting in so that the students could interact) - this is a building that works.

To commemorate that, it's our great pleasure to share with each of the Board members a copy of the Great Seal book. This is in commemoration of this particular day, and of all the faith and confidence that the Board of Trustees has had in creating this facility for our students. As Bob described it, with the Seal, we have the globe which represents the world today, the telescope which represents the future, and the book which represents the wisdom of the ages.

What we asked our students to do in the book contest was to imagine themselves as students 100 years from now. What words of wisdom would come from a student today, that 100 years from now, would still be meaningful? Words of wisdom that they would understand, that they would say "yeah that's the way things should be, and they would know it was from Miami. So I have 82 essays that were put together and as Bob pointed out, we weren't done yet. We also had the students in paper science produce the paper for the book, and we had the Delgado sisters in architecture do the drawings. This book very much symbolizes what the Student Center is all about, that the students are front and center. So, it's our great joy to have given each of you this book and I hope it will always have a treasured place in your homes.

So this is part of the campaign, and as we know, the campaign has been phenomenal and tomorrow night we'll fill in that little gap Tom teased us with here this morning. The campaign is the result of an enormous amount of work from an enormous number of people and of course the generosity of Alumni and friends and parents makes all the difference in the world. To recognize this and to commemorate it, we've also given you a copy of the new photo book called "For Love and Honor" which has pictures of Miami, historic pictures as well as contemporary pictures, that gives a sense of the stunning beauty of this campus. But as you look at them, it's not only the beauty of this campus that you see, but, as with the Student Center, you see the life of the University. For anybody who's been, these pictures immediately evoke all sorts of memories and experiences, this is as true today as it has ever been, and it will be true tomorrow as well.

So it is our absolute delight to share this with you as a commemoration of a very, very successful campaign whose impact on Miami is only beginning to be felt and will only grow as the years go by. And, by the way, this is for sale in the bookstore for those of you who are looking for Christmas presents. I also want to thank Deedie Dowdle and all of her staff who put this together. It was an inspired idea and we're very, very proud of this.

Next, I'd like to talk just a little bit about one of the other components that makes Miami so special, and that's our people. We're very delighted to have our new Vice President and our new Deans with us here today. We're very excited to add them to the senior leadership of the University. Later on, in a few moments, we're going to have Provost Gempesaw talk about the promotion of Assistant Professors to Associate Professor with tenure, and from Associate Professors to Full Professor. No decisions other than the original hiring decisions themselves are more significant to a University than the recognition of our faculty. These promotions are made with an extraordinary amount of care and are very much value driven. At Miami we seek faculty who share a passion for learning, share a passion for research, teaching, and for service. The combination of these things makes our faculty truly, truly extraordinary, so I'm looking forward with great anticipation to the presentation from the Provost on this. You know, if you recall from our 2020 goals, one of our foundational goals, the most important goal, was to promote a vibrant learning and discovery environment. It's these faculty who are at the heart of making that happen and I couldn't be more proud of them.

I also want to single out the staff at Miami University. Now, as you know, this has been a somewhat challenging winter and we have had to deal with some very, very difficult weather, which requires our staff to arrive at the University at 4:30 in the morning to clear the sidewalks to make holding class possible. We've had them working overtime, long hours, and they're just extraordinary. To make sure you understand exactly how difficult this is, I want to share with you a Tweet that I got from one of our students that just gave a typical example of how difficult and challenging it is at Miami. So you can see, the Tweet says, "Me walking to class this morning, Thanks @ resHodge" (the photo was of a deer walking in deep snow, covering all but its head), it's a little bit of humor, and I don't know that it ever got quite that bad, but it was pretty bad, and so a huge shout out and thanks to those on our staff who were involved in making sure that the campus stays safe and it's possible for class and activities to go on.

The other staff I particularly want to highlight are, the staff that have been involved in setting up the Armstrong Student Center. I think some of you got a flavor this morning, and if any of you spend any time with the staff you'll quickly get a sense of how proud they are to be in there, and how much they are trying to be innovative, and creative, and responsive. There's a lot of work to do in figuring out what this building is going to be, and so kudos to the staff who have taken this on.

Lastly, I just to talk about a couple of the activities I think really highlight what our students can do. I want to echo what Chair Mitchell said about the "J-Term." Numerically, it's far exceeded anything we could have expected. We had set a goal of 1,000 registrations and as noted, we had nearly 3,400 registrations so we certainly knocked it out of the park with the numbers, but there are three different dimensions to this I'd like to emphasize.

First, flexibility. From the beginning, the whole notion was to formally offer many different kinds of alternatives for people. But the idea was students might informally do things as well. I had a student in my office this week, for example, who came to talk to me. He had stayed at home, but he worked with friends on building a new non-profit company that they're putting together. Plus, they've got a new business, which is very clever; they're building kiosks which are designed to charge your cell phone. The idea is

you go and swipe your card and it identifies a little cubicle, the cubicle opens, you put your cell phone in, you plug it in, you close the cubicle, and you go away, and then you come back when your cell phone is done, it's a really clever idea. But the point is that this student used his time very, very productively to move ahead. Others have studied abroad, studied here on campus, participated in distance learning and e-learning - so many different options over all.

The second point that I would like to emphasize is that for very many students, this is the type of high impact, intense experience that really makes a difference. Chair Mitchell identified many of the places and activities that were offered; let me just highlight a couple of these. My personal favorite, which maybe doesn't make the point as well as many of the others, but it is my personal favorite, is the group of Inside Hollywood students that got to go on the set of N.C.I.S. which is my favorite T.V. show. So they got to spend time with Mark Harmon and have their pictures taken with him, and I'm absolutely green with jealousy that they got to do this. And then they went on and spent an hour with Conan; I don't know Conan because that's too late at night, but, N.C.I.S. that's a pretty cool thing.

I was sitting in the Armstrong Student Center in the Pulley Diner during its first week of operations, the first couple of days, and like the students I was waiting for quite a long time. We're still working on a few things here, but it's good to have more demand than you can satisfy. So I sat down on one of the stools to ask the students what they'd done for the "J-Term," and before I even asked, one of the students said "Oh, re sident Hodge, I'm so glad to see you; I was going to write you this letter."

I said, "What about?"

He replied "Well, I went on J-Term to Argentina and was part of a combined Spanish and Geology group of 13 students who went to Argentina for 4 weeks; we were in 4 different locations for a week at a time." He went on "it was the most fabulous experience of my entire life."

I have heard some version of that from so many students. He described that he lived with host families, receiving an immersion in Spanish. Every afternoon they would have lectures in Geology and then they were out in the field to experience the geological features of each area. It turned out, that very same evening, we had a reception for the folks from the University Senate and two of the members of the Senate were two of the faculty who were responsible for this class. Totally unconnected, they brought me a little gift from that class, and they relayed to me their experience. They said two things that demonstrate this intensity that I believe is so very important.

The first was, as they said, "You know, the first week was pretty crumby. The students were disorganized, and they were disoriented, because they were put into a situation which was not like any situation they had ever been in before. They were uncomfortable, they didn't like it, they wanted to go home, they were..... But, by the time they got to the last day, none of them wanted to return." This kind of transformative

impact is why we put such an emphasis on these immersive programs, whether its study abroad, or in Hollywood, or New York, or if it's in some service project, these are the kinds of experiences that transform our students forever; and they had this fabulous experience. The Geology Professor said this group of students when they took the final exam for this course scored higher than any class he had ever taught in the past. So obviously this high impact experience was not only about learning about themselves in the world, but about learning the subject as well.

The last example is from one of the students who works just outside the resident's Office who went to Nicaragua for two weeks. The first week was with a group of pre-med students, who went as a service project, and the second was with a class. What they did was to work side-by-side as assistants to doctors in Nicaragua, serving local, primarily poor, primarily rural populations. Again, it was called the most fabulous experience of his life. In those two weeks, those students served 4,000 patients, and had a phenomenal experience doing so.

The third point is innovation. Our faculty were phenomenal in simply addressing the question; "How do I cram a normal 15 week course into three or four weeks? How do I think about what my learning objectives, and can how I use this time very, very, productively?" We had a group of Chairs for dinner at Lewis Place, and to listen to them describe how their faculty adjusted to this challenge and adapted to it, was just absolutely phenomenal and in a very large number of cases what we found is that student outcomes were enhanced. The idea of having a single course can actually work for some students extremely well. One of the best examples of this is a finance course with over 100 students enrolled, taught by Steve Wyatt, the Chair of the Finance Department. At the beginning of the course he asked the students "How many of you have tried this course before?" And about 2/3 of the students raised their hand. It's a course that many students stumble on when they get going. Out of the 100+ students who began this course, only 4 didn't finish. So we had a tremendous outcome in terms of the success of our students based on the innovation and the creativity of our faculty.

My last point then is about our Spring Jobs Fair held earlier this week, the focus of which is on internships as well as jobs. We call it the Spring ICE (Internship and Career Expo) and I had the opportunity to go there and walk around and talk to employers who are seeking our students. I would typically go to the ones where there wasn't a line (to not to get in the way of students) and the questions I posed to the employers this year, as I pose to them each year, was "What are you looking for? How important is a major? What are the qualities you look for in a student? And why are you here at Miami?" There's a remarkable convergence on this. Yes, some of the firms have very specific, technical needs, but most of the firms are saying "You know, basically we're willing to consider almost anyone. But what we're looking for are students who have a great work ethic, students who know how to take the initiative, students that we can rely on, and that is why we're at Miami. That is why we're here."

I hope the examples that I've given you earlier point to the reasons why our students are so well prepared. We seek to attract precisely those students, academically ambitious students, students with a fire in their belly, students with a sense of initiative, students with values, and

students who are going to perform. And then our faculty and our staff work together to produce the most incredible environment, as we've seen in the Armstrong Student Center, we've seen in these other facilities, and we see in all of the success of this campaign.

Report of the Chair of University Senate Executive Committee

Dr. Steve Wyatt was unable to attend. However, Dr. Wyatt did submit a written report to the Academic and Student Affairs Committee, which is included in the Committee's minutes.

Report of the President, Associated Student Government

Mr. Charlie Schreiber, President, Associated Student Government, reported the following:

Good morning and thank you so much for allowing me to address you today. Today is a very special moment in the history of Miami. As all of you know, later this afternoon we will dedicate the Armstrong Student Center. I wanted to take a few moments this morning, and properly thank this body for turning this dream into a reality, and to share with you how important this building is to your Miami student body. In 2008 you approved the creation of a student center, but nothing as beautiful or meaningful could have ever been imagined. Without the continued support of the board and the administration this new home for students across campus would never have come to fruition. Last Monday morning when the doors of Armstrong officially opened, students flooded into the building. I walked around during lunchtime, and it was as if this building was always a Miami treasure. Students were studying the study rooms, getting milkshakes and burgers in the diner, and hanging out with friends in the Shade Family Room. This just shows how much the student body wanted and needed a student center. After two weeks of celebration in the building, the enthusiasm is more widespread than ever. It is impossible to walk into Armstrong without feeling a connection to Miami and to the student body. So I really want to thank all of you for your continued support in giving your students a new home on campus.

Another exciting addition to our life at Miami is the creation of the new winter term. I was fortunate enough to jump into a class and experience the new term before I graduate. Although my human sexuality class was a little more graphic than I thought I signed up for, I would not have been able to learn this new and different subject without the winter term. I think that is the real beauty behind taking classes during this time. Although it's nice to get ahead in your major, I think the real value is in experiencing new types of education and learning, taking classes outside your major, and going on an educational trip in a different country if you could not study abroad for a whole semester. The Miami plan is the base of our liberal education, but having this winter term allows students to truly go outside their educational comfort zone and learn something new. Our Miami University education is truly one of a kind, and this new addition, only adds to its uniqueness.

With that being said, I want to make sure that all Miamians can experience our coveted education for all four years. I truly believe in the need for a tuition guarantee policy. I had the opportunity to attend the Board of Trustees finance meeting yesterday, where this policy was

discussed. We need to continue these conversations, and I thank Dr. Creamer for being such a strong advocate for this on behalf of the students. Uncertainty is the driving factor in this case. After my last address to the board, a student who was here listening told me that she sets her hours as a student employee to make sure she has enough to pay for the semester. It is students like this who are most affected by the small tuition increase. Families and students who know that they have enough to pay for Miami when they are a freshman, but have to leave their sophomore or junior year because the extra couple hundred dollars, are the people who this policy would benefit the most. I want to thank the board for continuing these conversations. The student body wants a policy like this, and realizes that it would allow their friends and classmates to continue being RedHawks.

This leads to my final point today, and that is bystander intervention on campus. I have had the opportunity to speak all around campus these past two weeks about applying the I Am Miami initiative to bystander intervention. I believe this is the root of the I Am Miami initiative and I'm very excited student groups across campus are starting to understand this fact as well. The base for everything is being respectful of yourself and your own beliefs while also protecting the rights of others to have different views. I think the constant communication on issue is so important, because at the end of the day it is the students who have to take hold and make this initiative their own. Now that we have a new home on campus, students can interact more regularly and I think this is the time for I Am Miami and bystander intervention policies to become rooted in the student body.

Once again, I thank you so much for the constant work you do for our university. I am really looking forward to serving as your Student Body President for another semester, and very excited for things to come. I hope to see you all at the Armstrong Student Center Dedication later this afternoon. Thank You.

Academic and Student Affairs Committee

Report of the Committee Chair

Committee Chair Sue Henry reported the following:

The Academic and Student Affairs Committee of the Miami University Board of Trustees met on February 6, 2014. The meeting was called to order by committee chair Sue Henry. The committee went into executive session and, subsequently, opened its public session.

STUDENT TRUSTEES

This was Student Trustee Arianne Wilt's last committee meeting. She presented a final report summarizing the successes she has seen accomplished and the remaining challenges that she saw. The Chair and the committee expressed their appreciation for her service and hard work on the committee and for the University.

ASG UPDATES

ASG Secretary for Academic Affairs Stewart reported that he had received very enthusiastic feedback about the first Winter term. He also noted that students were enthusiastically embracing the Armstrong Student Center and the attendance at the first Snow Ball held at Armstrong was over 1,500 on a Thursday night.

UNIVERSITY SENATE

Professor Steve Wyatt submitted a written report reviewing the business conducted by the University Senate since the committee's last meeting.

PROVOST REPORT

Provost Gempesaw presented and the committee recommends approval of resolutions regarding two personnel appointments and three new degrees that will be presented today at the meeting of the full Board.

ENROLLMENT MANAGEMENT

Associate Vice President Michael Kabbaz reported on our great success in meeting our 2014 enrollment goals. As of February 6, 2014, we have set a new record number of applications receiving over 25,000. Our average ACT score is 27, the average GPA is 3.64 and the average curriculum strength is 13.3. All these numbers represent record highs for Miami. Our total number of applications is up by 15% and our non-resident applications are up by 25%. Each division also has experienced a significant increase in applications with the one exception of Education, Health and Society which essentially held even.

Applications for early decision were slightly reduced, but applications for early admission were significantly increased. This trend probably indicates that higher quality students are keeping their options open. Forty percent of the early decision acceptances were offered financial aid and 99% of the initial round of early admission acceptances were offered financial aid.

We now offer thirteen areas for University Academic Scholars and have issued 497 invitations to this program.

Vice President Kabbaz reviewed the family incomes of applicants and enrolled students. In the five years since the 2009-10 academic year, the median total family income of our enrolled students has risen by at least 24%. A similar trend is reflected in the median total income of our applicant pool. This was attributed to our increase in non-resident enrollment. We had an interesting discussion regarding the amounts and timing of financial aid.

COLLEGE OF ARTS AND SCIENCE

Dean Phyllis Callahan surveyed the many initiatives that CAS is engaged in for

curriculum, research, culture and outreach.

Recruitment and retention strategies – She focused on the many recruitment and retention activities undertaken by CAS that benefit Miami students and also strengthen partnerships with high schools, alumni and other external groups.

University Studies – Of particular interest was the University Studies major that has brought into the CAS fold those students who formerly were “undeclared” majors as well as students not directly admitted into the Farmer School of Business. There were 835 University Studies majors in Fall 2012 and 673 in Fall 2013. These students are considered potentially “at-risk” and thus receive a significant investment from the CAS advising staff and faculty advisors. This investment has paid off with a 90% rate of retention to the second semester for University Studies majors, and between a 60 and 65% admittance rate to the FSB for University Studies students.

Professional development – CAS is developing a four year professional development program called Strategies That Enhance Professional Success or “STEPS” that focuses on liberal arts students, alumni interactions and partnerships with Career Services. Involved in the program are curriculum offerings, internships, professional advising programs and development of online and hybrid courses that target the non-traditional Miami student.

Research and grants – Dean Callahan stressed the importance of research and graduate programs to the strength of the University and the growth of the students. Currently thirteen departments offer the three plus one bachelor and master degrees programs. CAS is identifying its major areas of strength in research and graduate programs. Once these are identified, CAS will focus on those areas and grow interdisciplinary research collaborations, increase the number of undergraduate students doing research and seek additional external funding.

CAS does face challenges including aging facilities, out-of-date classrooms and labs, and a need for additional advisors.

VICE PRESIDENT OF STUDENT AFFAIRS

Associate Vice President Mike Curme updated us on conversations he has had with campus and town stakeholders regarding the issue of alcohol use. He indicated that the Office of Student Affairs would have a new strategic plan for risk reduction of student drinking behaviors ready for implementation in Fall 2014.

TASK FORCE FOR THE PREVENTION OF SEXUAL ASSAULT

Kenya Ash, Director of the Office of Equity and Equal Opportunity and Title IX Coordinator, and Becca Getson, Sexual Assault Response Coordinator, reviewed the progress made toward fulfilling the recommendations of the Task Force on the Prevention of Sexual Assault. They noted that Miami has revised its policies, procedures and education programs to comply with recent federal legislation including the Campus Sexual Violence Elimination Act and also addressed President Obama’s recent initiative on prevention of sexual assault.

SERVICE LEARNING AND COMMUNITY ENGAGEMENT

Monica Ways, Director of the Office for Community Engagement and Service, discussed the various programs through which the Miami campuses are engaged with the communities around them. She noted the successes in community engagement and service learning achieved by Miami students is evidenced by the total impact of the services provided by our students, and that Miami University has received The Presidential Award for Higher Education Community Service.

INTERCOLLEGIATE ATHLETICS

Athletic Director David Saylor presented an overview of the athletic facilities and a description of the Gross Family Student-Athlete Development Center and their use by our student athletes.

WRITTEN REPORTS

The following written reports also were submitted:

- Academic “Good News“ by Provost Bobby Gempesaw
- “Strategic Priorities Task Force, Priority #13, Interdisciplinary Teaching and Research” by Associate Provost Carolyn Haynes
- Student Affairs “Good News” by Interim Associate Vice President of Student Affairs, Mike Curme, and Assistant Vice President of Student Affairs Scott Walter
- “Program Review and Assessment” by Associate Dean of Students Gwen Fears and Director of Budgeting and Technology Tim Kresse
- “Academic Intervention” by Interim Director of the Rinella Learning Center Christina Carrubba-Whetstone
- “Student Housing Occupancy Update” by Director of Housing, Contract and Meal Plans Brian Woodruff
- “Construction Project Update” by Associate Vice President of Facilities and Operations Cody Powell
- “Update on Development” by Vice President for Advancement Tom Herbert

Resolutions

Resolution for the Promotion and the Award of Tenure of Faculty and the Resolution for the Promotion and the Award of Continuing Contracts for Librarians

It was proposed that the resolution for faculty and the resolution for librarians be considered together, in a single vote. There being no objections, the resolutions were consolidated for Board consideration.

Provost Gempesaw introduced and spoke in support of the resolutions, highlighting several individuals who were being tenured and or promoted. The Provost commented:

Good morning, Board of Trustees' Chair, Sharon Mitchell, and other distinguished members of the Board. The granting of tenure and promotion is one of the most important decisions made at the University as the excellence of a university begins with outstanding faculty. The promotion and tenure process at Miami University involves comprehensive review by external peers and internal reviews by the department, the division, the University Promotion and Tenure Committee, the Provost and the President. Miami seeks to find a balance among teaching, scholarship and creative activities, and service. The faculty recommended to the Board for promotion and tenure are considered to be teacher-scholars and engaged learners, challenging students to become involved in creative and scholarly activities.

PROMOTION TO PROFESSOR

I am very pleased to highlight accomplishments and educational experiences of the following faculty who are recommended to the Board for promotion to professor.

Eric Bachmann is recommended for promotion to professor in the department of computer science and software engineering. Dr. Bachmann joined Computer Science and Software Engineering department in 2001 and was granted tenure in 2008. He received a B.A. in mathematics and computer science from the University of Cincinnati. Upon completion of his undergraduate work at UC, he worked with the RCA Missile Test Project at Cape Canaveral, Florida, followed by service in the United States Navy. He completed his M.S. and Ph.D. degrees in computer science at the Naval Postgraduate School, where he served as a lecturer and a Research Assistant Professor. Professor Bachmann excels in the classroom and is considered by his chair to be "...a strong, dedicated teacher..." whose teaching excellence extends beyond the classroom. Bringing research into the classroom and incorporating students into his research is one of Professor Bachmann's passions. An external reviewer noted that his research on the Huge Immersive Virtual Environment or HIV, the world's largest virtual environment, as one of the most impressive works in this area, and has resulted in over \$2 million in grant funding from the Army Research Office and the NSF. He holds two patents; has one patent pending; and has published in top-rated, high-impact journals in his field and in refereed articles in conference proceedings. In 2009, he was awarded the division's Outstanding Researcher Award. In conclusion, his chair states that in all areas, teaching, advising, scholarship, and service, Professor Bachmann exceeds the department's expectations for promotion to the rank of professor.

Michael Brudzinski is recommended for promotion to professor in the department of Geology and Environmental Earth Science. Dr. Brudzinski joined the Geology department in 2004 and was granted a leave to complete a postdoctoral fellowship at the University of Wisconsin-Madison. He returned in 2005 and was promoted to associate professor with tenure in 2010. He is also an affiliate faculty in the department of physics. He received his B.S. from Eckerd College in St. Petersburg, Florida, and his Ph.D. from the University of Illinois, Urbana-Champaign in Geophysics. His chair summarizes his accomplishments as presenting "...the most well-rounded and strongest case for promotion in rank to professor...during my 29-year

tenure.” He is considered one of the leading seismologists of his generation with a continuous record of publication in high-impact journals in his field. His research has been supported by grants totaling in excess of \$1 million, including a NSF Foundation Early CAREER Award, and over \$400,000 of student/postdoc funding. He states that the goal of his work is to help people better understand the physical processes happening in the Earth. His external review letters from internationally recognized scientists confirm the assessment of the department chair and department promotion committee that Miami is indeed fortunate to have Dr. Brudzinski on the faculty.

Thelma Horn is recommended for promotion to professor in the department of kinesiology and health. Dr. Horn joined the Kinesiology and Health department in 1986. She was promoted to associate professor with tenure in 1989. She received her B.A. in psychology from Calvin College; her M.A. in physical education coaching behavior from Western Michigan University; and her Ph.D. from Michigan State University in the area of psychology of sport and physical activity. Professor Horn’s teaching and advising have been judged as excellent by both her department chair and department promotion committee as evidenced by the high marks she received from students and colleagues. She has received numerous commendations for her teaching, including the Richard T. Delp Outstanding Faculty Award and the Crystal Apple Award. Her scholarship has also been judged as excellent; her external reviewers concur that Professor Horn’s research has made significant contributions to the field. In addition to her book, *Advances in Sport Psychology*, currently in its 4th printing, she has published in the top journals in her field and presented papers at national and international conferences, including invited keynote addresses. She has received funding from both internal and external sources, including a grant from the NIH, in support of her research. In addition to her teaching, advising, and research contributions, Professor Horn has been active in her professional associations and provided extensive service to her department, division, and the University. One of her external reviewers judges Dr. Horn to be in rare company, among the top ten in the world, within the field of sport psychology.

AWARD OF TENURE AND PROMOTION TO ASSOCIATE PROFESSOR

I am now pleased to highlight accomplishments and educational experiences of the following faculty who are recommended to the Board for tenure and promotion to associate professor.

Charles (Chuck) Moul is recommended for tenure and promotion to associate professor in the department of economics. Professor Moul joined the Economics department in 2008. He received his B.A. in economics and political science from Miami University and his Ph.D. in economics from Northwestern University. His primary areas of interest are industrial organization and econometrics with secondary interests in public finance and information economics. In 2012-13, he received the Richard K. Smucker Teaching Excellence Award for Outstanding Junior Professor in the Farmer School of Business. Professor Moul has established a reputation as an excellent, challenging, and engaging teacher and mentor. His chair notes particularly his willingness to provide one-on-one mentoring to his students and extending his advising duties beyond his current students to former students and to those students seeking advice on pursuing a graduate degree. Since coming to Miami, Dr. Moul has been a very

productive scholar, with a solid trajectory as noted by one of his external reviewers. His chair and the department P&T committee noted that eleven of his papers have been published or accepted for publication in peer-reviewed economics journals. Dr. Moul's service to the department has been exemplary for his leadership in revitalizing student interest and participation in the department's honors program, the enthusiasm he brings to the economics club, and his willingness to supervise honors and M.A. students' exit papers, two of which are on the path to publication.

Christin Schillinger is recommended for tenure and promotion to associate professor in the department of music. Christin Schillinger joined the Music department in 2009 from the University of Nevada-Reno where she was an assistant professor and the bassoon and music theory coordinator. She received her bachelor of music from Northwestern University; her master of music in performance from Michigan State; and her doctor of musical arts in performance from Arizona State. Professor Schillinger's peer and student evaluations provide evidence of her successes in the classroom and her one-on-one studio teaching. Her students' performances have been well received in venues both on and off campus. Several of her students performed at the prestigious International Double Reed Society (IDRS) Conference and have been accepted to perform at festivals in Italy and The Julliard School. Dr. Schillinger has maintained a continuous and impressive record in the area of bassoon performance as a solo artist, recognized by her annual performances at the IDRS through a competitive juried selection and solo recitals throughout the U.S. at prestigious universities. Her 2009 CD entitled Bassoon Sounded includes five world premier recordings. Her scholarly writings include publishing in the premier journal in her profession and publication of a book in progress. One of her external reviewers finds her interpretations to be "...creative and her command of the bassoon to be excellent;" another describes the quality of Professor Schillinger's playing "...as of the highest order."

Alana VanGundy is recommended for tenure and promotion to associate professor in the department of political science with an appointment on the regional campus in justice and community studies. Professor VanGundy has been a member of the regional campus faculty since 2004, serving as an adjunct and visiting faculty prior to her appointment as assistant professor in 2008. She received her B.A. in criminal justice and psychology from the University of Dayton and her M.S. in criminal justice and Ph.D. in sociology with a focus on criminal justice from the University of Cincinnati. She is a consultant for numerous local, state and federal law enforcement agencies, programs for at risk women and victims of domestic violence. Professor VanGundy has played a major role in developing the criminal justice program on the regional campuses, designing and teaching a wide range of courses. Today, the program enrolls hundreds of students at the associate and bachelor degree levels. Her prolific service contributions to the profession and community were recognized when she received the YWCA Outstanding Woman of the Year in Education and the Miami University Hamilton Service awards in 2013. In addition to her teaching and service contributions, Professor VanGundy has applied for and received internal and external grants to fund her research, which includes two books and publications in top-ranked journals. Her chair comments that she is "...one of the most successful and thoughtful instructors I have ever seen...a great teacher...who easily meets and exceeds the standards of high-quality teaching and advising."

LIBRARIANS

There are also several librarians who applied and are being recommended to the Board for promotion and/or continuing contract. As with the granting of tenure, the awarding of continuing contract and/or promotion involves a similar rigorous review process of the individuals' credentials according to the University Libraries' governance document.

I would like to introduce one of the librarians being recommended for a continuing contract and promotion to associate librarian.

Elias Tzoc is recommended for promotion to associate librarian and continuing contract. Elias joined the University Library in 2007. He currently serves as the digital initiatives librarian in the University Libraries. He received a B.S. in information systems management from Galileo University in Guatemala and an M.S. in information studies from the University of Texas at Austin with a focus on developing and providing access to digital resources in academic libraries. His primary area of excellence is in scholarship and creative activities. His accomplishments include significant work on complex software products. An example is his contributions to the DSpace software, which is noted by one of his external reviewers as "...thorough and valuable to the broader community. ... [and] shows creativity and a willingness to collaborate virtually with others around the world." The DSpace community consists of over 1,500 institutions worldwide. Elias has also applied his technical skills to projects that engage students in critical issues, such as his work on the Freedom Summer National Conference and with the Center for American and World Cultures.

Chair Sharon Mitchell and other distinguished members of the Board of Trustees, President Hodge and I recommend that the Board approve the applications of the candidates for promotion and/or tenure listed in the Board resolution. We also recommend that the Board approve the promotion and continuing contracts of the librarians as listed in the Board resolution.

rovost Gempesaw's presentation is included as Attachment C.

Mr. Ridenour moved, Mr. Budig seconded, and by voice vote Resolutions R2014-19 and R2014-20 were unanimously adopted with nine Trustees voting in favor and none opposed.

RESOLUTION R2014-19

BE IT RESOLVED: that the Board of Trustees hereby approves the recommendations for promotion and tenure effective July 1, 2014:

For Promotion to PROFESSOR

Eric	Bachmann	Computer Science and Software Engineering
Samir	Bali	Physics
Susan	Brehm	Speech Pathology and Audiology
Michael	Brudzinski	Geology and Environmental Earth Science
Devon	DeVecchio	Marketing

For Promotion to PROFESSOR (continued)

Melany	Fisk	Biology
Gerald	Granderson	Economics
Suzanne	Harper	Mathematics
Yvette	Harris	Psychology
Thelma	Horn	Kinesiology and Health
Elizabeth	Howard	Computer and Information Technology
Raul	Ianes	Spanish and Portuguese
Joseph	Johnson	Psychology
Lei	Kerr	Chemical, Paper and Biomedical Engineering
Glenn	Muschert	Sociology and Gerontology
Marie Elise	Radina	Family Studies and Social Work
Amit	Shukla	Mechanical and Manufacturing Engineering
David	Tierney	Chemistry and Biochemistry
James	Tobin	Media, Journalism and Film

For TENURE and PROMOTION to ASSOCIATE PROFESSOR

Champike	Attanayake	Mathematics
Annette	Bollmann	Microbiology
John	Bowblis	Economics
Dana	Cox	Mathematics
	Dabney-	
Carole	Smith	Chemistry and Biochemistry
Darrel	Davis	Educational Psychology
Khalid	Eid	Physics
Daniel	Farley	Mathematics
Anne	Farrell	Accountancy
Brooke	Flinders	Nursing
Kimberly	Hamlin	American Studies Program
Jae Woo	Jeong	Mathematics
Martin	Johnson	History
Mark	Krekeler	Geology and Environmental Earth Science
Katherine	Kuvalanka	Family Studies and Social Work
Charles	Moul	Economics
Nirmala	Naresh	Mathematics
Leighton	Peterson	Anthropology
Paul	Schaeffer	Biology
Christin	Schillinger	Music
Monica	Schneider	Political Science
Amy	Summerville	Psychology
Alana	Van Gundy	Political Science/Justice and Community Studies

RESOLUTION R2014-20

BE IT RESOLVED: that the Board of Trustees hereby approves the recommendation for promotion to associate librarian and the awarding of continuing contract, effective July 1, 2014, as follows:

Kathie Gibson
Jason Michel
Lindsay Miller
Masha Stepanova
Elias Tzoc

BE IT RESOLVED: that the Board of Trustees hereby approves the recommendation for promotion to principal librarian, effective July 1, 2014, as follows:

Susan Hurst
Jenny Presnell

Affirmation of Appointment, Mr. Jerome Conley, Dean, University Libraries

Provost Gempesaw spoke to the excellent performance of Jerome Conley and asked the Board to affirm his appointment as Dean and University Librarian. Mr. Conley then addressed the Board,

Following Mr. Conley's remarks, Mr. Shroder moved and Mr. Crain seconded a motion to affirm Mr. Conley's appointment. Mr. Crain then spoke regarding the distinguished public service record of Mr. Conley. Following Mr. Crain's remarks, the full Board, by voice vote, unanimously approved the resolution and affirmed the appointment of Dean Jerome Conley, with nine Trustees voting in favor and none opposed.

RESOLUTION R2014-21

BE IT RESOLVED: that the Board of Trustees hereby affirms the appointment of

Jerome Conley
as Dean and University Librarian,
and
Associate Librarian,

effective January 1, 2014.

Affirmation of Appointment, Dr. Matt Myers, Dean Farmer School of Business

Provost Gempesaw spoke to the excellent qualification of Matthew Myers and asked the Board to affirm his appointment as Dean of the Farmer School of Business. Dr. Myers then addressed the Board.

Following Dr. Myer's remarks, Mr. Wilson moved, Mr. Ridenour seconded, and by voice vote the resolution was unanimously approved and the appointment of Dean Matthew Myers was affirmed, with nine Trustees voting in favor and none opposed.

RESOLUTION R2014-22

BE IT RESOLVED: that the Board of Trustees hereby affirms the appointment of Matthew Myers as Dean, Farmer School of Business effective May 1, 2014.

BE IT FURTHER RESOLVED: that the Board of Trustees also hereby approves the recommendation for the awarding of tenure to

Matthew B. Myers
as Professor, Department of Marketing,
Mitchell P. Rales Chair in Business Leadership
and
Dean, Farmer school of Business

to also become effective on May 1, 2014.

Creation of a Bachelor of Science in Forensic Science and Investigation

Provost Gempesaw introduced and spoke in support of the creation of a Bachelor of Science degree in Forensic Science and Investigation.

Mr. Shroder moved, Mr. Ridenour seconded, and by voice vote the resolution was unanimously adopted, with nine Trustees voting in favor and none opposed.

RESOLUTION R2014-23

BE IT RESOLVED: that the Board of Trustees hereby approves the establishment of a new undergraduate degree program, the Bachelor of Science Degree in Forensic Science and Investigation, within the College of Professional Studies and Applied Science.

BE IT FURTHER RESOLVED: that the Board of Trustees also hereby endorses two proposed majors: Forensic Science and Forensic Investigation.

Creation of a Bachelor of Science in Civic and Regional Development

Provost Gempesaw introduced and spoke in support of the creation of a Bachelor of Science degree in Civic and Regional Development.

Mr. Bhati moved, Mr. Budig seconded, and by voice vote the resolution was unanimously adopted, with nine Trustees voting in favor and none opposed.

RESOLUTION R2014-24

BE IT RESOLVED: that the Board of Trustees hereby approves the establishment of a new undergraduate degree program, the Bachelor of Science Degree in Civic and Regional Development, within the College of Professional Studies and Applied Science.

Creation of a Master of Fine Arts in Creative Writing

Provost Gempesaw introduced and spoke in support of the creation of a low-residency Master of Fine Arts degree in Creative Writing.

Mr. Bhati moved, Mr. Budig seconded, and by voice vote the resolution was unanimously adopted, with nine Trustees voting in favor and none opposed.

RESOLUTION R2014-25

BE IT RESOLVED: that the Board of Trustees hereby approves the establishment of a new graduate degree program, the Low-Residency Master of Fine Arts in Creative Writing.

Finance and Audit Committee

Report of the Committee Chair

Committee Chair Mike Armstrong began by extending his appreciation to the Trustees who, while not Committee members, attend and add value to the meetings. He then reported the following:

The Finance and Audit Committee of the Miami University Board of Trustees met on February 6, 2014. The meeting was called to order by committee chair Mike Armstrong. The committee went into executive session and, subsequently, opened its public session.

The Committee considered eleven resolutions during the meeting. Nine of the resolutions are for capital project planning and construction. The remaining two are associated with a future debt issuance that was informally approved at the December meeting. Vice President Creamer will explain each of the resolutions as they are introduced later in the meeting. All of the resolutions were endorsed at the meeting and are recommended to the Board of Trustees for approval.

The Committee devoted most of its time yesterday to several reports. The first of these was the annual review of the condition of university facilities. Much progress has been made in recent years on the preservation and modernization of university facilities but with a facility replacement value in excess of \$2.6 billion, there has to be an ongoing investment to keep pace with the continuous aging of these facilities. Given recent projects like Kreger Hall and several residence and dining hall projects, the overall condition of university facilities improved from 32.28% to 30.08% just above the University's target of 30%.

The Committee devoted a significant portion of the meeting to discussing budget planning. Presentations were made on the long-term budgets for both the Oxford and regional campuses with the primary focus being new revenue generation. New revenue is critical to the future of all of Miami's campuses, with the Oxford Campus being further ahead in meeting this objective following the successful implementation of several new revenue initiatives this year. Vice president Creamer provided the Committee with charts depicting the current and projected performance for each of the Oxford Campus' revenue initiatives and informed the Committee that it had exceeded its new revenue target for this year.

Dean Michael Pratt discussed the regional campus plan with the Committee including several new degree programs and the expected enrollments from these programs. He also addressed the Committee's questions about the long-term financial outlook for the campuses. The Committee asked that the regional campus discussion be continued at the April meeting.

The Committee's next report was on the investment policies and performance of the non-endowment. Given the growth in the amount invested since the market declines of 2008 -2009, it was concluded that it is an appropriate time to reduce the large fixed income allocation associated with these investments thereby lowering the portfolio's negative exposure to rising interest rates and improving the long-term growth prospects for investment earnings. Further discussions about the investment policies and asset allocation strategies are planned for a future meeting.

The creation of a tuition guarantee for future Miami students was also discussed at yesterday's meeting and several student leaders joined the committee for this discussion. A very important priority for the Board is how to make planning for the cost of attending Miami easier and more transparent for students and parents. Because the creation of a tuition guarantee program involves a larger tuition increase in the first year, there was much discussion about whether the added increase would outweigh the benefits of tuition certainty. The Committee also discussed whether the tuition guarantee should be optional or the only tuition plan. Vice President Creamer was asked to provide the committee at the next meeting with more analysis about the impact of a tuition guarantee program in an inflationary environment and how the larger increase in the initial year of the program has affected student recruitment at other institutions that have implemented a tuition guarantee.

In addition to the resolutions and the discussion topics that I mentioned, the Committee also received and considered several routine reports as part of its agenda.

Ordinances and Resolutions

No Ordinances were presented to the Board.

Resolutions

There were nine capital project resolutions for Board consideration. It was proposed that the nine capital project resolutions be considered together, in a single vote. There being no objections, the resolutions were consolidated for Board consideration.

Dr. Creamer spoke to the resolutions, explaining that this high activity is common at this time of year. He also explained, with the exception of Shideler Hall, which is dependent on State funding that is expected to be awarded later this semester, that funding is already in place for the projects with none being dependent on new bonding. He also explained the Hayden Park project is funded 100% through pledges from donors.

Mr. Crain moved, Mr. Ridenour seconded, and by voice vote the nine capital project resolutions were unanimously adopted, with nine Trustees voting in favor and none opposed.

The text of the nine resolutions follows. Additional information regarding the resolutions is provided as Attachment D.

East Quad Renovation

RESOLUTION R2014-26

WHEREAS, the East Quad Renovation plan includes the renovation of five existing residence halls, one dining hall and related infrastructure improvements; and

WHEREAS, Miami University has determined that the cost of the project can be reduced through a single Design Build project delivery method; and

WHEREAS, the Board of Trustees previously approved a budget not to exceed \$5,050,000 in contracts for the preconstruction phase of the project including the planning, design, cost estimating, and other services necessary to prepare the Guaranteed Maximum Price (GMP); and

WHEREAS, Miami University has identified bond funds in the amount of \$88,280,000 to execute the construction of the East Quad Renovation project; and

WHEREAS, the East Quad Renovation project represents the largest renovation project to date for the Long Range Housing Master Plan; and

WHEREAS, the Design Build Guaranteed Maximum Price (GMP) is to be received in February 2014;

NOW, THEREFORE, BE IT RESOLVED: that the Board of Trustees authorizes the Vice President for Finance and Business Services and Treasurer, in accordance with all State guidelines, to proceed with the award of contracts for the East Quad Renovation project with a total project budget not to exceed \$93,330,000.

Western Campus Site improvements and Landscape

RESOLUTION R2014-27

WHEREAS, the Western Campus Site Improvements and Landscape project involves restoration of grounds, improvements to pedestrian crossings, and development of walks and drives on the Western Campus in areas impacted by the execution of the Long Range Housing Master Plan projects; and

WHEREAS, Miami University has determined that the cost of these projects can be reduced by combining them into a single Construction Manager at Risk award of contract; and

WHEREAS, Miami University has solicited proposals and has identified a Construction Manager at Risk to execute the work; and

WHEREAS, the selected construction manager is already under contract on the Western Campus Residence Halls project and has offered additional cost savings to execute the Western Campus Site Improvements and Landscape project as a change order to its existing contract; and

WHEREAS, Miami University has identified local funds in the amount of \$5,870,000 for the Western Campus Site Improvements and Landscape project;

NOW, THEREFORE, BE IT RESOLVED: that the Board of Trustees hereby authorizes the Vice President for Finance and Business Services and Treasurer, in accordance with all State guidelines, to proceed with the Western Campus Site Improvements and Landscape project by executing a change order to the Western Campus Residence Halls project with a value not to exceed \$5,870,000.

Peabody Hall Renovation

RESOLUTION R2014-28

WHEREAS, it has been almost twenty years since Peabody Hall was last renovated and a modest investment in this facility will allow it to continue to be operated for the benefit of student residents and certain academic functions; and

WHEREAS, the timing of these improvements will also allow for changes that will enable Peabody Hall to be served by the new geo-thermal plant in the future; and

WHEREAS, Miami University has determined that cost savings can be achieved by combining the projects into a single Construction Manager at Risk contract; and

WHEREAS, Miami University has identified local funds in the amount of \$1,900,000 for the Peabody Hall Renovation; and

WHEREAS, the Guaranteed Maximum Price (GMP) is to be received in March 2014;
and

WHEREAS, the Board of Trustees desires to award a contract to the most responsive and responsible Construction Manager at Risk;

NOW, THEREFORE, BE IT RESOLVED: that the Board of Trustees hereby authorizes the Vice President for Finance and Business Services and Treasurer, in accordance with all State guidelines, to proceed with the award of contract for the Peabody Hall Renovation project with a total project budget not to exceed \$1,900,000.

HDRBS Improvements 2014 Projects

RESOLUTION R2014-29

WHEREAS, the summer improvement plan for residence and dining halls will affect thirteen residence halls better ensuring these facilities are adequately maintained and able to meet the needs of students until the buildings are renovated later in the Housing and Dining Master Plan; and

WHEREAS, the summer improvement plan will also make minor improvements to the Recreational Sports Center which has now been in operation for twenty years; and

WHEREAS, Miami University has determined that the cost of the project can be reduced by combining these projects into a Single Prime project delivery method; and

WHEREAS, Miami University has identified local funds in the amount of \$1,500,000 for the project; and

WHEREAS, the \$1.5 million budget includes a cost of construction estimate of approximately \$1.1 million; and

WHEREAS, the State of Ohio allows the award of contracts up to 110% of the construction estimate necessitating a bid variation contingency of \$110,000 in addition to the \$1.1 million construction budget; and

WHEREAS, the design is being completed and receipt of bids is planned for April 2014;
and

NOW, THEREFORE, BE IT RESOLVED: that the Board of Trustees hereby authorizes the Vice President for Finance and Business Services and Treasurer, in accordance with all State guidelines, to proceed with the award of contract for the HDRBS Improvements 2014 project with a total project budget not to exceed \$1,500,000.

Shideler Hall Renovation Design Fees

RESOLUTION R2014-30

WHEREAS, it is anticipated that the Ohio General Assembly will appropriate funding to renovate Shideler Hall for Miami's geosciences program during the current legislative session; and

WHEREAS, Miami University, in anticipation of the appropriation, intends to complete the design, cost estimating, and preconstruction services required to develop a Guaranteed Maximum Price (GMP) for a subsequent resolution once the funding is appropriated; and

WHEREAS, the Board of Trustees desires to award a contract to the most responsive and responsible Construction Manager at Risk;

NOW, THEREFORE, BE IT RESOLVED: that the Board of Trustees authorizes the Vice President for Finance and Business Services and Treasurer, in accordance with all State guidelines, to proceed with the award of contract for the preconstruction phase of the Shideler Hall Renovation project which includes planning, design, estimating and all related preconstruction services necessary to prepare the Guaranteed Maximum Price (GMP) for a budget not to exceed \$2,500,000.

HUB Quad Tunnel Top Replacement

RESOLUTION R2014-31

WHEREAS, the "tunnel top" system has been in place on the Oxford Campus for over thirty years and needs to be replaced; and

WHEREAS, a new more efficient design for the tunnel top has been developed and the deteriorated sections of the current system are being replaced in phases; and

WHEREAS, the HUB Quad Tunnel Top Replacement project involves the installation of the new tunnel top design in the area of the HUB; and

WHEREAS, Miami University has determined that the cost of the project can be reduced by employing the Single Prime project delivery method; and

WHEREAS, Miami University has identified local funds in the amount of \$1,500,000 for the HUB Quad Tunnel Top Replacement project; and

WHEREAS, the \$1.5 million budget includes a cost of construction estimate of approximately \$1.2 million; and

WHEREAS, the State of Ohio allows for the award of contracts up to 110% of the construction estimate necessitating a bid variation contingency of \$120,000 in addition to the \$1.2 million construction budget; and

WHEREAS, the design is being completed and receipt of bids is planned for April 2014; and

WHEREAS, the Board of Trustees desires to award a contract to the lowest responsive and responsible bidder;

NOW, THEREFORE, BE IT RESOLVED: that the Board of Trustees hereby authorizes the Vice President for Finance and Business Services and Treasurer, in accordance with all State guidelines, to proceed with the award of contracts for the HUB Quad Tunnel Top Replacement project with a total construction budget not to exceed \$1,500,000.

Art Quad Electrical Modifications and CPA HVAC Replacement

WHEREAS, Miami University has developed a long-term plan to upgrade the antiquated 4160-volt electrical distribution system that still exists in parts of the Oxford campus today; and

WHEREAS, Miami University has identified local funds in the amount of \$1,305,000 for the Art Quad Electrical Modifications and the Center for Performing Arts (CPA) HVAC Replacement project in support of the long-term plan; and

WHEREAS, the \$1,305,000 budget includes a cost of construction estimate of approximately \$1,140,000; and

WHEREAS, the State of Ohio permits contracts to be awarded up to 110% of the construction estimate necessitating a bid variation contingency of \$114,000 in addition to the \$1,140,000 construction budget; and

WHEREAS, the receipt of bids is planned for April 2014; and

WHEREAS, the Board of Trustees desires to award a contract to the most responsive and responsible bidder;

NOW, THEREFORE, BE IT RESOLVED: that the Board of Trustees hereby authorizes the Vice President for Finance and Business Services and Treasurer, in accordance with all State guidelines, to proceed with the award of contract for the Art Quad Electrical Modifications and CPA HVAC Replacement project with a total project budget not to exceed \$1,305,000.

Hamilton Campus, Phelps Hall HVAC Improvements

RESOLUTION R2014-33

WHEREAS, the age of some regional campus buildings make it necessary that major repairs occur to aging building systems in order for the buildings to continue to be operated; and

WHEREAS, the replacement of aging heating, air conditioning and ventilation systems in Phelps Hall will also help to lower utility costs for the Hamilton Campus; and

WHEREAS, Miami University has determined that the cost of the project can be reduced by combining the projects into a Single Prime contract; and

WHEREAS, Miami University has identified funds in the amount of \$1,100,000 for the Hamilton Campus Phelps Hall HVAC Improvements, including \$555,100 appropriated by the State of Ohio; and

WHEREAS, the \$1,100,000 budget includes a cost of construction estimate of approximately \$907,000; and

WHEREAS, the State of Ohio permits contracts to be awarded up to 110% of the construction estimate necessitating a bid variation contingency of \$90,700 in addition to the \$907,000 construction budget; and

WHEREAS, the receipt of bids is planned for March 2014; and

WHEREAS, the Board of Trustees desires to award a contract to the most responsive and responsible bidder;

NOW, THEREFORE, BE IT RESOLVED: that the Board of Trustees hereby authorizes the Vice President for Finance and Business Services and Treasurer, in accordance with all State guidelines, to proceed with the award of contract for the Hamilton Campus Phelps Hall HVAC Improvements project with a total project budget not to exceed \$1,100,000.

Hayden Park Addition

RESOLUTION R2014-34

WHEREAS, Miami University has received gifts totaling \$1.5 million and pledges totaling \$1.5 million for constructing a baseball support facility as part of the Hayden Park complex; and

WHEREAS, Hayden Park Addition – Baseball Support Facility involves construction of dedicated locker rooms, coaches' offices, and support space on the third base side of Hayden Park; and

WHEREAS, the receipt of proposals is planned for April 2014; and

WHEREAS, the Board of Trustees desires to award a contract to the most responsive and responsible Construction Manager at Risk;

NOW, THEREFORE, BE IT RESOLVED: that the Board of Trustees hereby authorizes the Vice President for Finance and Business Services and Treasurer, in accordance with all State guidelines, to proceed with the award of contract for the Hayden Park Addition – Baseball Support Facility Project with a total budget not to exceed \$3,000,000.

Bond Resolutions

There are two resolutions. Dr. Creamer explained this is because the action of the Board is the first steps and the approval of the Ohio Board of Regents is also required. The proposed bond issuance has been discussed in depth by the Finance and Audit Committee, and this will be last issuance for several years. The amount issued represents approximately one half of the required funds, with the remaining cost to be financed internally.

Dr. Creamer informed the Board that the resolutions also includes in the resolution is the refinancing of 2005 bonds does not add to the debt profile of the University or the duration of the debt, but helps in lowering the overall expense of that debt.

Bond, Authority to Proceed

Mr. Ridenour moved, Mr. Budig seconded, and by voice vote the resolution was unanimously adopted, with nine Trustees voting in favor and none opposed.

RESOLUTION R2014-35

Authorization to Seek Ohio Board of Regents Approval for Bond Issue

WHEREAS, the Board of Trustees has approved the residence hall renewal master plan and the cost of the next phase of the plan is estimated to be approximately \$150 million; and

WHEREAS, alternative financing options were formally evaluated following a request for information from prospective private partners; and

WHEREAS, the evaluation of the alternative financing options found these options to be more expensive and not appropriate for major renovation projects like those planned for the renewal of the University's residence and dining halls; and

WHEREAS, it may be advantageous from time to time to refund certain outstanding obligations of the University which may include all or a portion of the Series 2005 General Receipts Bonds, outstanding in the aggregate principal amount of \$63.48 million; and

WHEREAS, the approval of the Ohio Board of Regents is required prior to the issuance of these bonds;

NOW, THEREFORE, BE IT RESOLVED: that the Board of Trustees hereby authorizes the Vice President for Finance and Business Services and Treasurer to request approval of the Ohio Board of Regents to issue bonds in an amount not to exceed \$200 million; and

BE IT FURTHER RESOLVED: that, upon approval of the Ohio Board of Regents to issue bonds, the Vice President for Finance and Business Services and Treasurer is hereby authorized to take all actions necessary to issue bonds in an amount not to exceed \$200 million.

Bond Issuance

Mr. Ridenour moved, Mr. Budig seconded, and by voice vote the resolution was unanimously adopted, with nine Trustees voting in favor and none opposed.

RESOLUTION R2014-36

PROVIDING FOR THE AUTHORIZATION, ISSUANCE AND SALE OF NOT TO EXCEED \$200,000,000 OF GENERAL RECEIPTS REVENUE AND REFUNDING BONDS, SERIES 2014, OF MIAMI UNIVERSITY, APPROVING A SIXTH SUPPLEMENTAL TRUST AGREEMENT AND AUTHORIZING THE FISCAL OFFICER TO TAKE CERTAIN ACTIONS.

The text of Resolution R2014-36 is provided in Attachment E.

Student Trustee Reports

Student Trustee Graham Bowling, reported as follows:

The past two months were a whirlwind of exciting activities here in Oxford, around the U.S. and abroad. Students are still talking about their exciting Winter Term adventures. Whether students braved the extreme wind chills for class in Oxford or basked in the warm Costa Rican sun, the Winter Term was undoubtedly a major success throughout the university. I am looking forward to future years and many more incredible opportunities for students to enhance their lives and Miami experience.

Last week, over 1,500 students attended the Snow Ball event and enjoyed all that the Armstrong Student Center has to offer. After officially opening this semester, it is clear that the Armstrong Student Center is revolutionizing student involvement and opportunities at Miami. It is amazing to witness the transformative power of a beautiful new space. It is obvious to all who enter that this is the heart of student activity. Students are studying, planning, networking, relaxing and laughing in all corners of the building. I can't wait to see newly admitted students and their families visit during the upcoming 'Make It Miami' days. Thank you to the Armstrong family and all donors for your generous gifts and dedication to enable this impact on Miami's campus.

This semester, I am considering a range of opportunities to engage my role as a Student Trustee. I would like to schedule meetings with each university dean as well as students within a wide spectrum of university programs in order to gain the perspectives of these individuals and ultimately find opportunities to enhance the student experience at Miami.

I am also interested in student employment on Miami's campus. I will investigate opportunities to engage the working student population by learning their job-specific experiences and instances for growth.

Earlier this week, I was privileged to attend the lecture in The Harry Wilks Theatre featuring General Joe Ralston, a 1965 Miami graduate. The general challenged his audience with, “As Americans, we need to open our worldview”. Reflecting on the general’s lecture, I realized how proud I am of this university. Miami’s celebrated liberal education allows students to expand their purview throughout the world. Our campus reaches far beyond the confines of Oxford, OH. We are an increasingly attractive source of higher education to thousands of students around the world.

This semester, I am enrolled in “Creativity and n entrepreneurship” in the Farmer School of Business. My creativity professor, Dr. Jim Friedman, tells us each day that, “everything we do makes a statement”. At Miami, we are making a lasting and extraordinary statement. The successful completion of the Campaign for Love and Honor makes a statement. A beautiful new Armstrong Student Center makes a statement. I am eager to witness the positive impact of these statements for years to come.

I hope everyone enjoys their weekend here in Oxford planning for future endeavors and celebrating all of the university’s accomplishments.

Other Business

Resolution to reappoint National Trustee C. Michael Armstrong

Chair Mitchell thanked Mr. Armstrong for his valuable service and his willingness to extend his term.

Mr. Ridenour moved, Mr. Budig seconded, and by voice vote the resolution was unanimously adopted, with nine Trustees voting in favor and none opposed.

RESOLUTION R2014-37

BE IT RESOLVED: that the Board of Trustees re-appoints C. Michael Armstrong as a National Trustee, for a term ending June 30, 2014.

Resolution of Appreciation for Student Trustee Arianne Wilt, Attachment

Chair Mitchell explained that the term of a Student Trustee is two years and the Ms. Wilt’s term expires on February 28, 2014. Chair Mitchell also explained the Ms. Wilt could by attend today and that the Trustees were able to express their gratitude for her service during the Academic and Student Affairs Committee meeting the day before.

Mr. Bhati moved, Mr. Budig seconded, and by voice vote the resolution was unanimously adopted, with nine Trustees voting in favor and none opposed.

RESOLUTION 2014-38

**Resolution of Appreciation to
Arianne R. Wilt**

WHEREAS, Arianne R. Wilt's term as a student member of the Miami University Board of Trustees ends on February 28, 2014;

NOW, THEREFORE BE IT RESOLVED: that the members of the Board of Trustees do hereby express to Arianne Wilt their appreciation for her service to this Board and to the Miami student body, and offer their best wishes for good health and good fortune in all her future endeavors.

Done, by the Miami University Board of Trustees, this Seventh Day of February, Two Thousand Fourteen at Miami University, in the City of Oxford, County of Butler, State of Ohio, during the Two Hundred and Fifth year of the University's Charter.

Adjournment of Meeting

With no other business to come before the Board, Mr. Ridenour moved, Mr. Bhati seconded, and by unanimous voice vote the meeting was adjourned at 12:00 p.m.



T. O. Pickerill II
Secretary to the Board of Trustees

University Advancement Report

Tom Herbert, JD

Vice President for University
Advancement

Topics

The Miami University Campaign For Love and Honor

- Campaign Update
- Campaign Impact
- Post Campaign



Campaign Update

The Miami University Campaign For Love and Honor

- Status
- Impact



Campaign Closed – Hidden Total

The Miami University Campaign

For Love and Honor

Gifts Booked as of Dec. 31, 2013:

\$_____ million

CY13: \$58.2 million

CY12: \$39.3 million

Impact on Miami

The Miami University Campaign For Love and Honor

- Scholarships
- Faculty Support
- Facilities



Scholarship Impact

The Miami University Campaign For Love and Honor

\$132 million in scholarship support

- Nearly 600 newly endowed scholarships
- Access Initiative created



Scholarship Impact

The Miami University Campaign For Love and Honor

“The moment I received my acceptance letter and financial aid package, I remember seeing a much brighter future for myself than I had ever expected. I am where I am today BECAUSE of my Miami Experience.”

Angela Bainter '12, Access Scholar



Scholarship Impact

The Miami University Campaign For Love and Honor

“The Ray Flodin Scholarship has given me the freedom to both focus on my education and gain experiences in the community without having to worry about punching the clock. It’s made all the difference in my life.”

Sarah Duncan '15



Scholarship Impact

The Miami University Campaign For Love and Honor

“I wouldn’t be where I am today without scholarship support....When I see a new technological advancement or design, I ask myself ‘Why can’t I?’”

Justin Eddie '12



Scholarship Impact

The Miami University Campaign For Love and Honor

“I don’t know how to fully thank those whose gracious generosity helps those who need it the most, other than to pursue my education gratefully...”

Danae Tolle '14



Faculty Impact

The Miami University Campaign For Love and Honor

More than \$31 million for faculty development,
plus \$16 million for research

33 newly endowed chairs and professorships



Faculty Impact

“He’s winning teaching awards, he’s with students at all hours of the day and night, and he keeps connected with those students after they graduate.”

About Mark Lacker, who holds the John W. Altman Clinical Professorship in Entrepreneurship



Faculty Impact

The Miami University Campaign For Love and Honor

“Writing is essential to academic preparation and success, and I’ve never been at a university that embraces that like Miami.”

Kate Ronald, who holds the Roger and Joyce Howe Professorship, and is Director of the Howe Writing Initiative



Faculty Impact

The Miami University Campaign For Love and Honor

“Student success is as much about what we are enabling our students to pursue as it is about what we are doing as faculty and staff.”

Brian Kirkmeyer, Karen Buchwald Wright Assistant Dean for Student Success



Facility Impact

The Miami University Campaign For Love and Honor

\$107 million for capital projects



Facility Impact

Armstrong Student Center – Phase One

Official building dedication: Feb. 7, 2014



Facility Impact

Farmer School of Business Building

Open – August 2009



Facility Impact

Goggin Ice Center

Open – August 2006



Facility Impact

Hamilton Campus Conservatory

Open – Fall 2005



The Miami University Campaign For Love and Honor

Post Campaign



Advancement's Post-Campaign Development Targets

The Miami University Campaign For Love and Honor

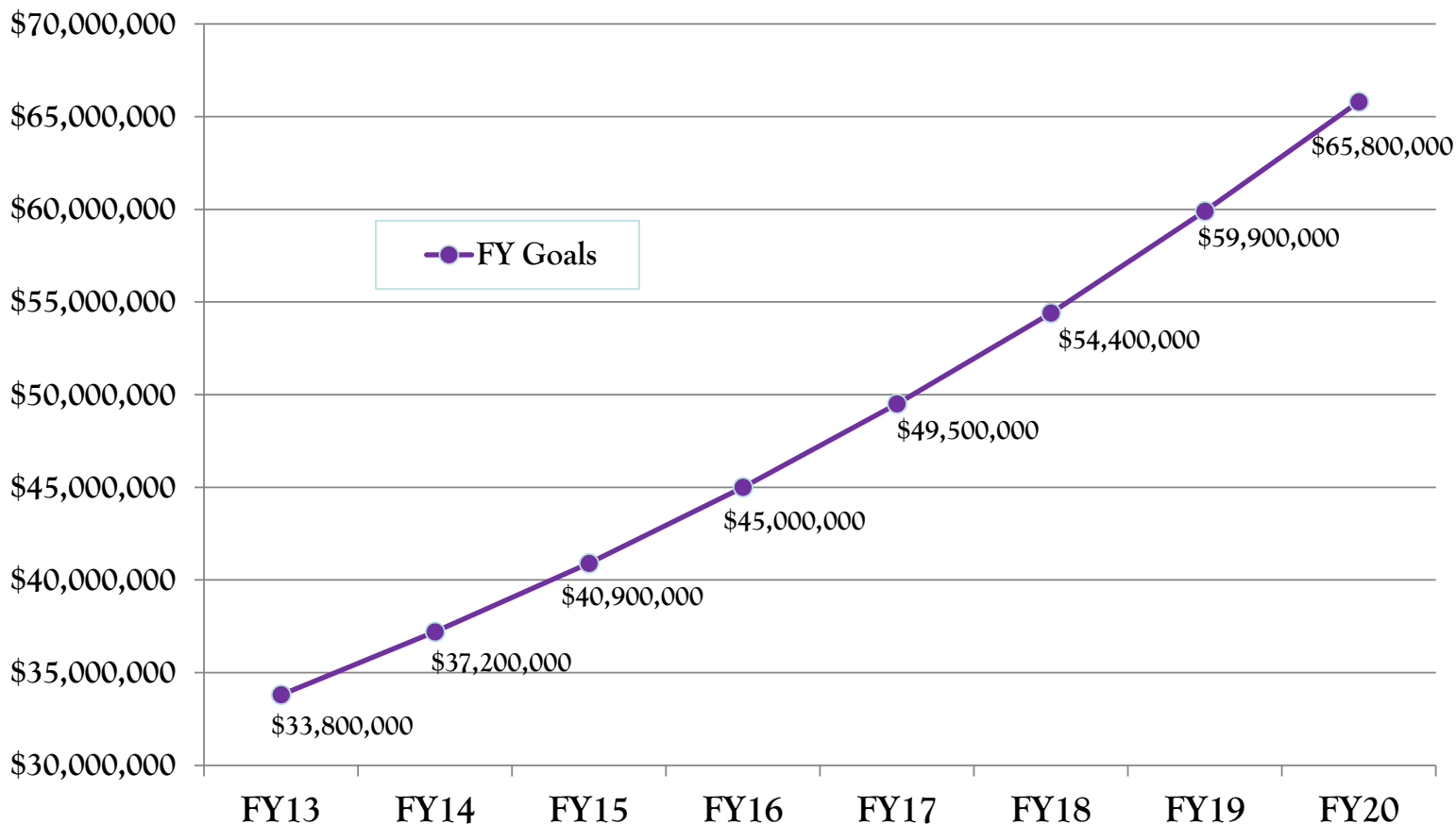

* Based on Miami's 20/20 Plan

Progress Toward FY14 Fundraising Goal

The Miami University Campaign For Love and Honor

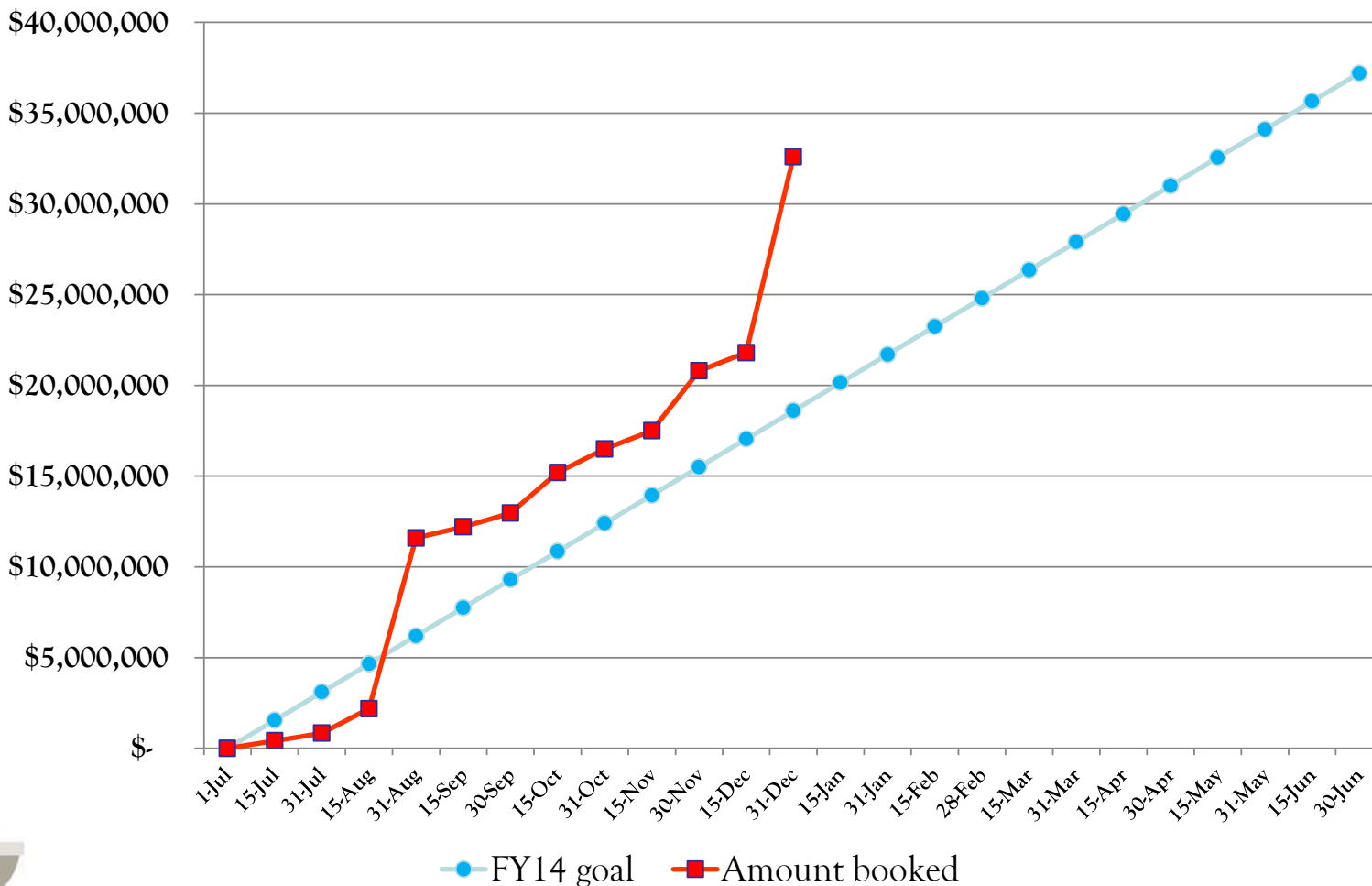

Post Campaign Priorities

The Miami University Campaign For Love and Honor

- Priorities Identified
 - Endowed scholarships for incoming students
 - Armstrong Student Center – East Wing
 - ICA Initiative
 - Faculty support
 - Residence hall renovation

Top Priority: Scholarship Initiative

The Miami University Campaign **For Love and Honor**

- Scholarship Match Program
 - New endowed recruitment scholarships
 - Marketing material close to completed
 - Official “roll out” in March 2014
 - Already closed approximately \$3.9 million in gifts

Scholarship Initiative

The Miami University Campaign For Love and Honor

Scholarship Match Specifics

- Title: *Match the Promise*

- *\$50K minimum gift payable over 4 years – but awarded immediately*
- *Miami match is 5% of the gift value each year for 8 years*
- *First 4 years the donor's gift grows without a distribution*
- *Example below: \$100K gift , paid \$25K per year over four years*

Scholarship Payment/Distribution	2014	2015	2016	2017	2018	2019	2020	2021
Donor Distribution	-0-	-0-	-0-	-0-	\$5K	\$5K	\$5K	\$5K
University Match	\$5K	\$5K	\$5K	\$5K	\$5K	\$5K	\$5K	\$5K

Scholarship Initiative

The Miami University Campaign For Love and Honor

Growth in Endowment Value

example: \$1 million gift (\$250,000 over 4 years),
assuming 6% annual return

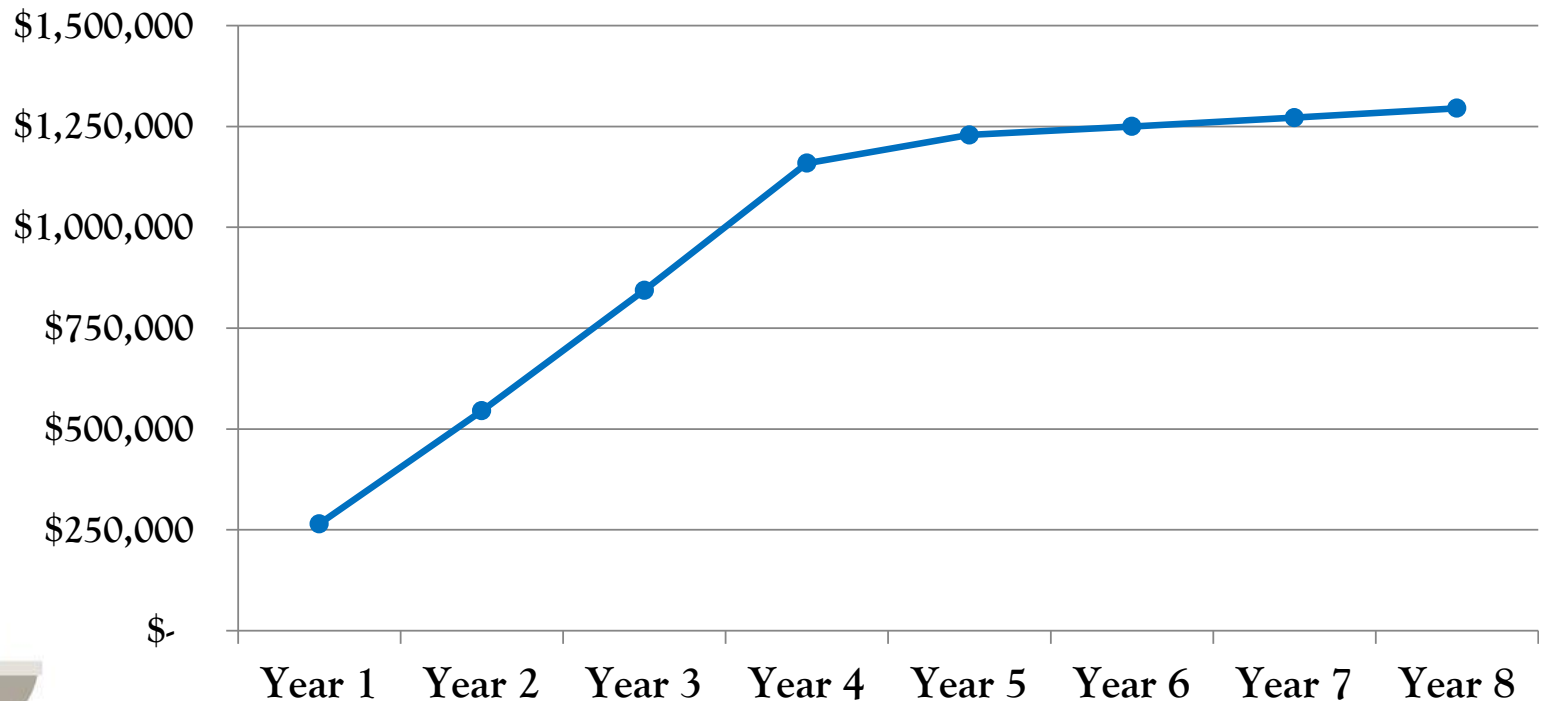

Questions?



Thank you!





MIAMI UNIVERSITY

The Armstrong Student Center:
“Bringing the Great Seal to Life”

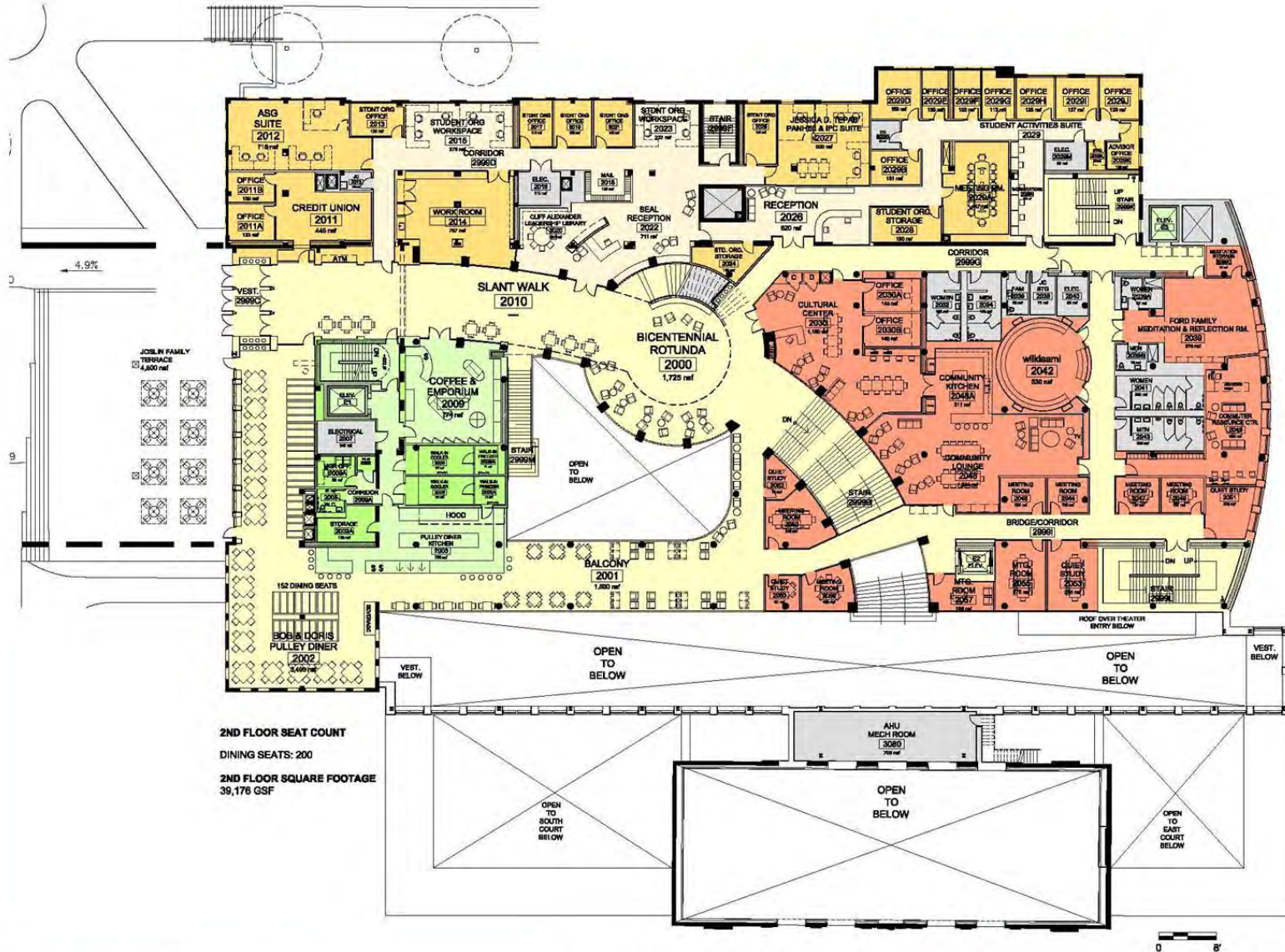

SECOND FLOOR PLAN - PHASE 1

September 28, 2010





Bicentennial Seal Location Along Rotunda Stair
Miami Seal Aligned with Slant Walk

February 16, 2011



MIAMI UNIVERSITY

Oxford, OH

William Rawns Associates, Architects, Inc., Boston, MA | BHDP Architecture, Cincinnati Ohio | Richard Burck Associates, Inc., Somerville, MA

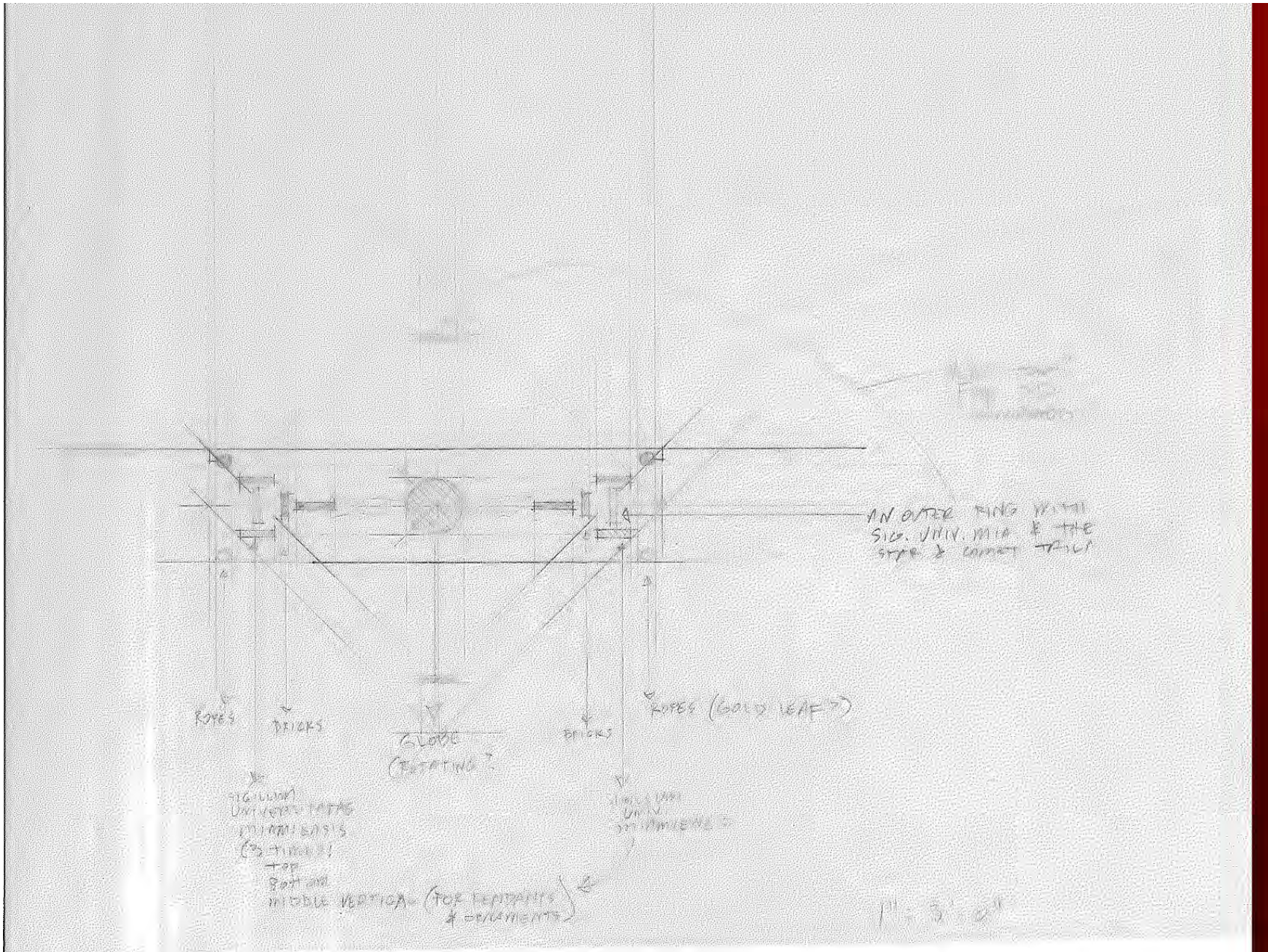

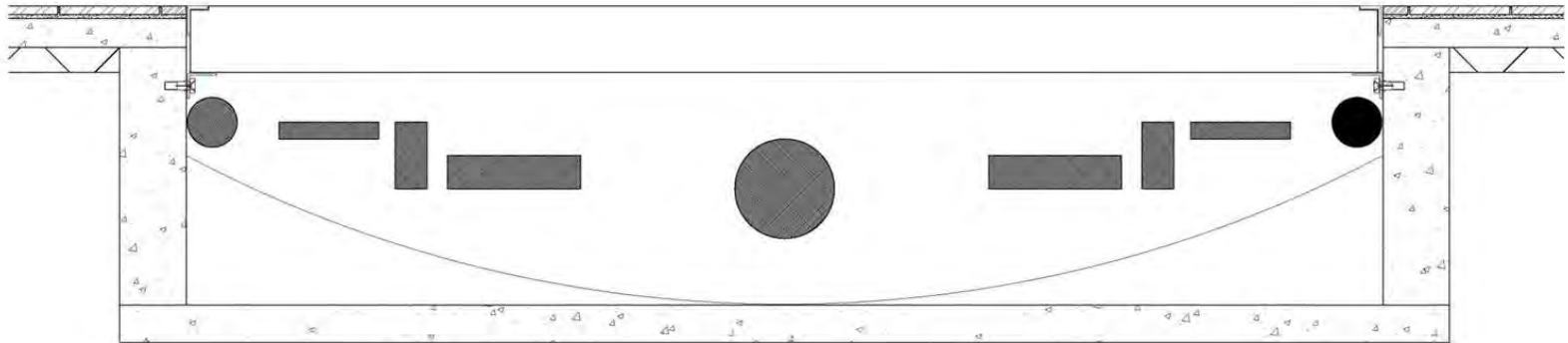











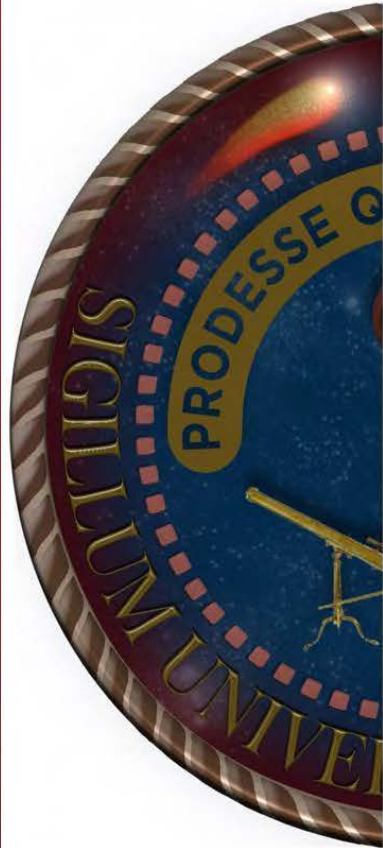













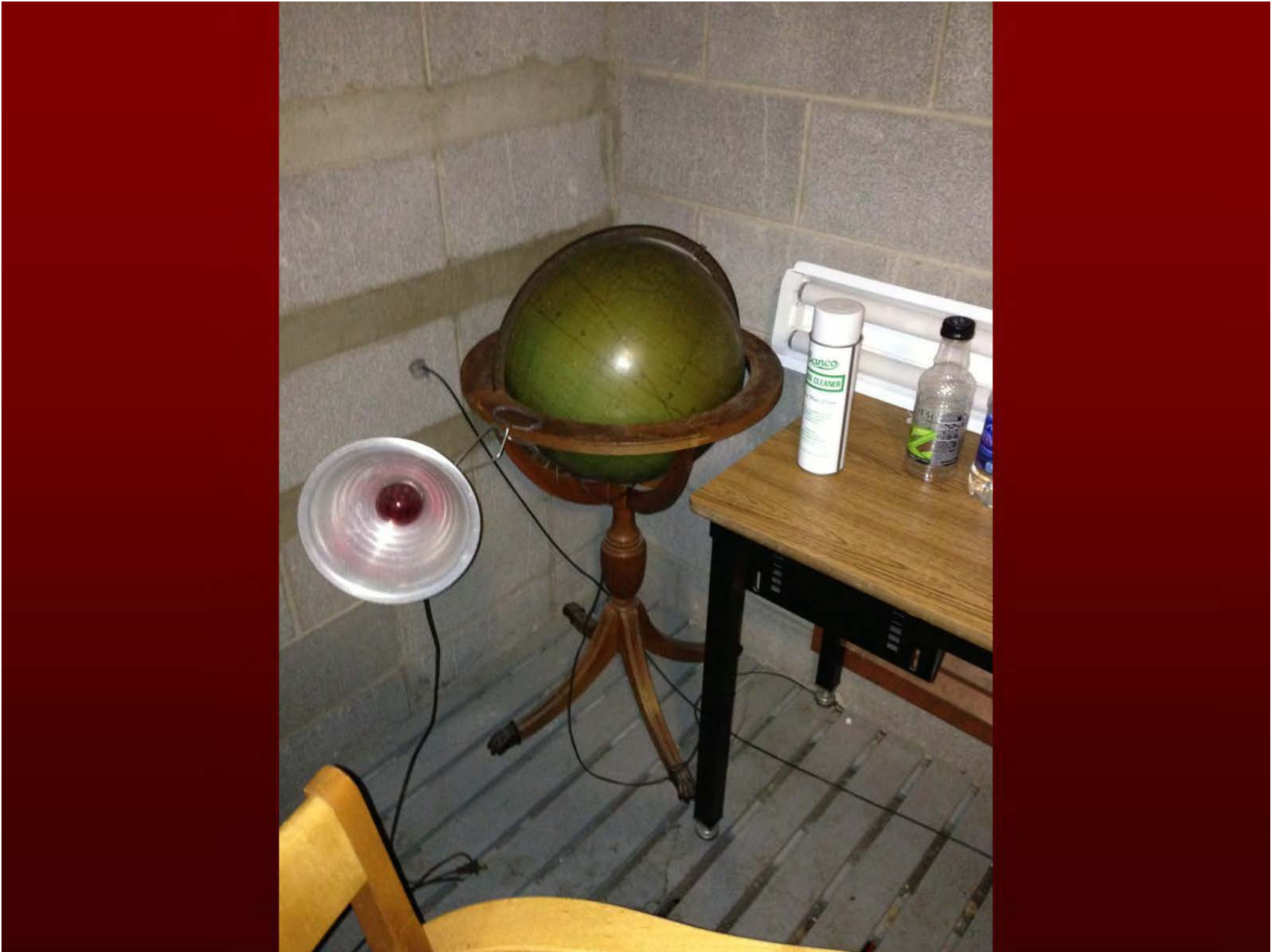









Great Seal Book Writing Contest - Howe Writing Center

MIAMI UNIVERSITY

HOWE WRITING CENTER

Home
About
ECWCA 2014 Conference
Locations and Hours
Contact Us

Great Seal Book Writing Contest

**Write Your Way Into Miami History:
The Great Seal Writing Contest**



In 2014, Miami will open the Armstrong Student Center, a structure that literally builds on the past and will nurture Miami students into the future. In March 2013 President Hodge asked the Miami student body to mark this occasion by showcasing their writing in the Great Seal of Miami University in the new Bicentennial Rotunda. The Rotunda will house a replica of the Miami University Great Seal, measuring twelve feet across and set three feet down into the floor (see artist's rendering below). The Great Seal includes three elements in a circle: an open book represents the accumulated wisdom of the centuries, passed on to the current generation through their reading. The globe symbolizes the present moment shared by all peoples, while the telescope points to the future yet to be discovered.

President Hodge invited students to "write" the book that stands within the Great Seal. The book will hold a living collection of student writing, captured in contemporary time, but speaking both to our heritage and imagining our own legacy.

To contribute to this book, contests were asked to compose a response to the following question:

As they pass the Great Seal in the Bicentennial Rotunda of the Armstrong Student Center, future generations will look for wisdom and wit in your words. In your Miami experience, what wisdom have you gained from the University's heritage that you would like to pass on? In other words, what values, beliefs, and experiences connect "Old Miami" and "New Miami"?

Length: 1809 words or less
Submission deadline: April 2, 2013
Contest open to: Miami undergraduate students, all campuses

Awards:

- Grand Prize: \$2,000 cash + the winning essay will be printed on the open page in the book
- \$1,000 for best essay for each of the other three classes (first year through senior)
- Other submissions will make up the remaining pages of the book

Twelve finalists (3 from each class) were selected by a committee of Miami faculty, staff, and students (with all names and identifying information removed so that selection was completely anonymous). Top essays from each class were voted on from among the finalists (also on an anonymous basis) by Miami students the week of April 26, 2013, and the Grand Prize winner was selected by the awards committee from among the 12 finalists.

The Next Steps: Now that the winners have been selected, the Great Seal Book will be produced—entirely by



12' diameter

An open book within the seal, symbolizing accumulated wisdom, will feature Miami student writing

STUDENT RESOURCES – UNDERGRAD AND GRAD

- [Make an appointment](#)
- [Information about appointments](#)
- [Calendar of workshops and events](#)
- [Other writing centers at Miami](#)
- [Writing advice online](#)
- [Student organizations for writers](#)
- [Places to publish your writing](#)
- [Writing competitions and awards – open to any major](#)
- [Becoming a writing major](#)
- [Becoming a consultant at the Howe Center](#)
- [Writing Boot Camps for graduate students](#)
- [Private editing services \(for a fee\)](#)
- [Miami's academic integrity website](#)
- [Quick Questions](#)

FACULTY AND TA RESOURCES

- [Ask a question, request support](#)
- [Writing Boot Camps for Faculty](#)
- [May Workshop](#)
- [Student Review of Assignments Service](#)
- [Writing Center Info for Syllabi](#)
- [Calendar of workshops and seminars](#)
- [Resources for teaching with and about writing](#)
- [Assignments Created by Miami Faculty](#)
- [Grants for faculty, departments, and programs](#)
- [Miami's academic integrity website](#)
- [College of Arts and Sciences Writing Policy – Resources and accomplishments](#)
- [Private editing services \(for a fee\)](#)

FOLLOW US



[http://writingcenter.lib.muohio.edu/?page_id=3330\[10/29/2013 4:10:45 PM\]](http://writingcenter.lib.muohio.edu/?page_id=3330[10/29/2013 4:10:45 PM])





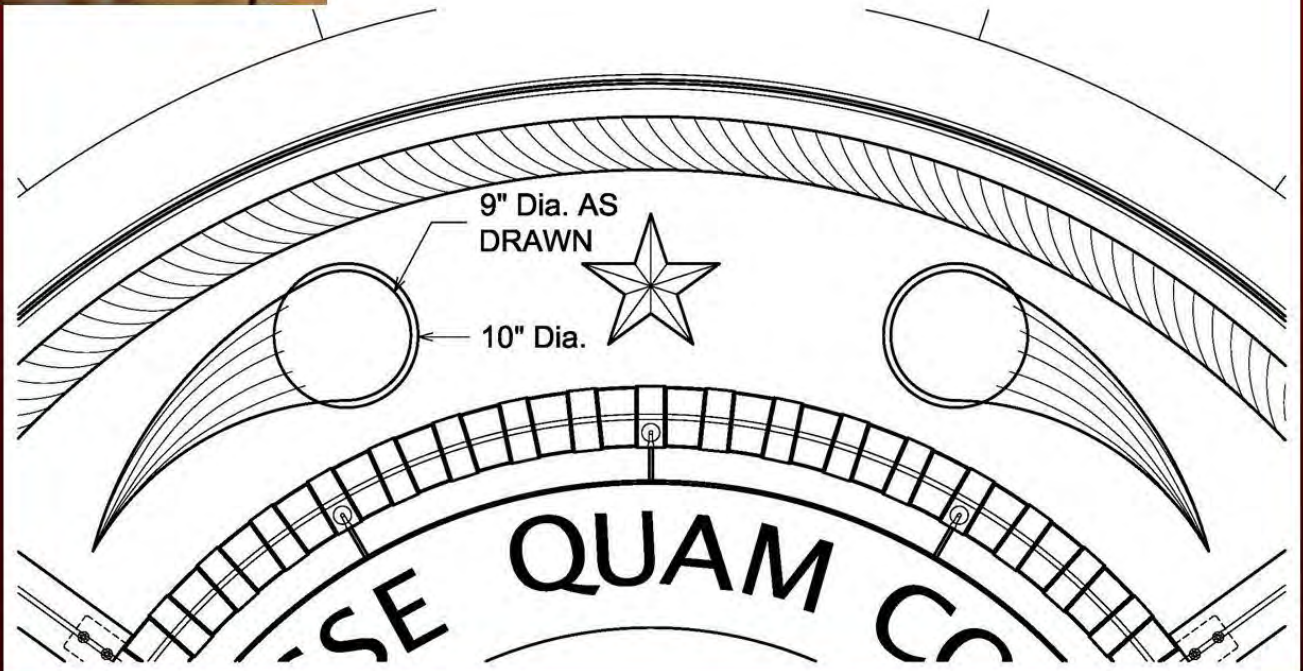

































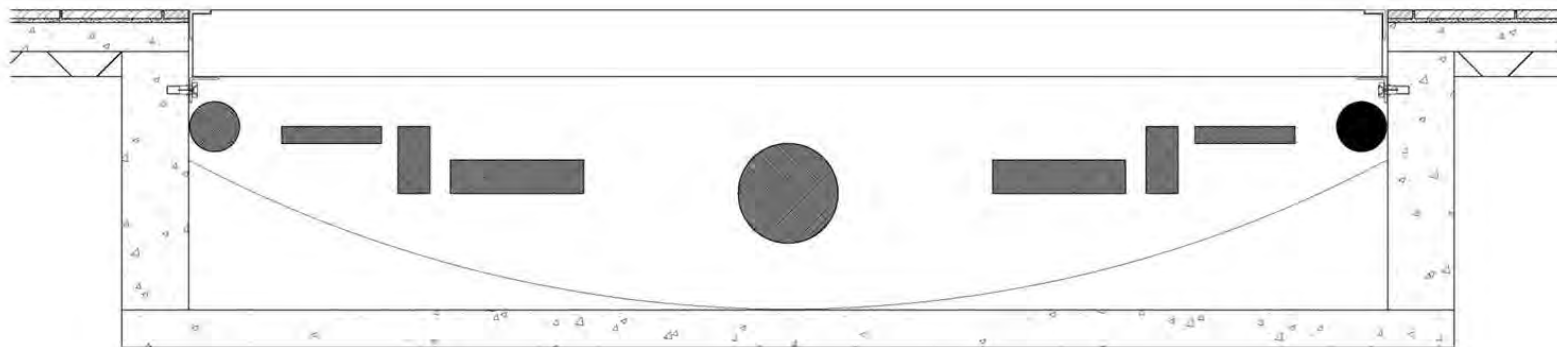

**Going from a schematic design concept...
To actual working construction documents.**





 **Exhibit**
Concepts
big ideas, bigger results.

today



the bigger the idea, the bigger the results.

October 2013
Surf's Up! (web-surfing that is)
ECI Launches New Corporate Website

1 MIAMI UNIVERSITY SEAL
X0.100 Scale: 1/2" = 1'-0"

2 SECTION
X0.100 Scale: 1/2" = 1'-0"

3 DETAIL
X0.100 Scale: 3" = 1'-0"

4 DETAIL
X0.100 Scale: 3" = 1'-0"

MIAMI UNIVERSITY SEAL

Exhibit Concepts
INCORPORATED
10010 Woodland Court, Vanables, Ohio 45377
www.exhibitconcepts.com

MIAMI UNIVERSITY SEAL

Owner:
Miami University
655 East High Street
Oxford, Ohio 45056

Designer:
Matt Brandberry
Exhibit Concepts
790 Crossroads Court
Vanables, Ohio 45377

Construction Drawings

Check appropriate box:

Approved as shown.

Approved as noted.

Not approved as noted. Please review and re-submit.

Designer's Signature and Date

Owner's Signature and Date

Copyright © 2012 All Rights Reserved

Drawn for:
Submittal

Drawn by:
M. Lewis

Date:
12-11-12

Revision Dates:

2-13-13	
2-26-13	

The drawing was formatted for a 24" x 36" sheet - 1/4" (9.525 mm) plot scale

Job #
D12Q2494

Page #
X0.100

8/12/13

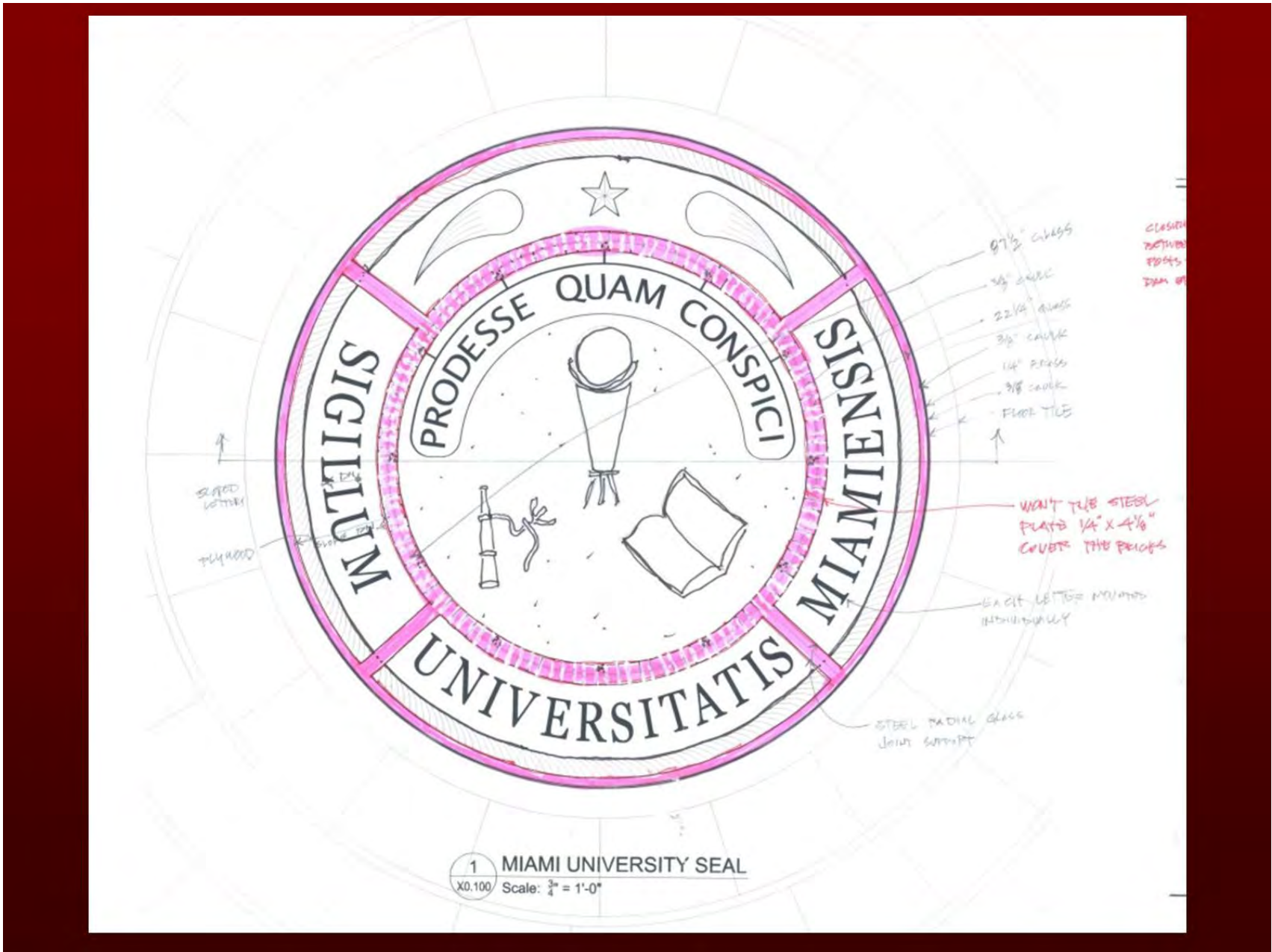

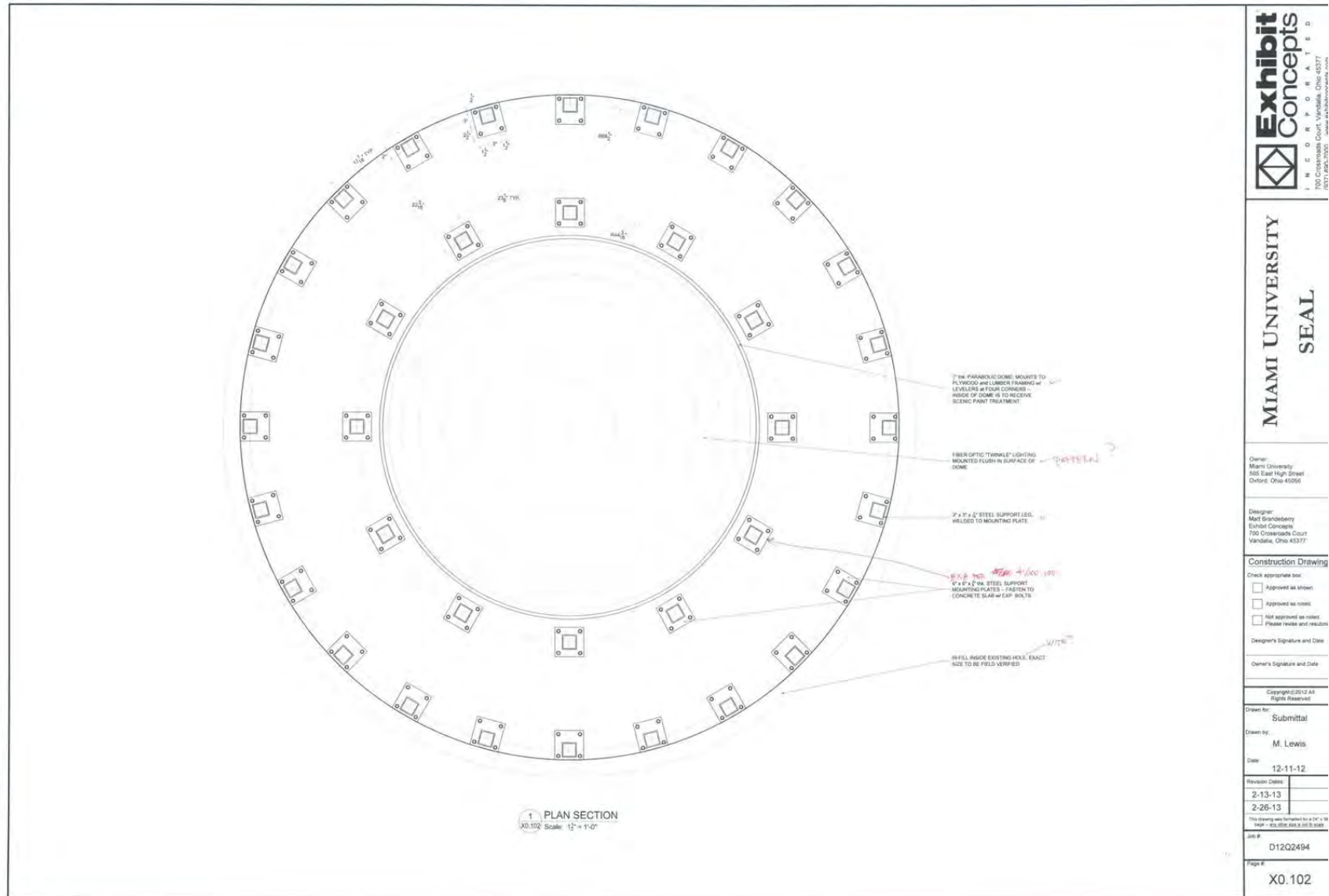

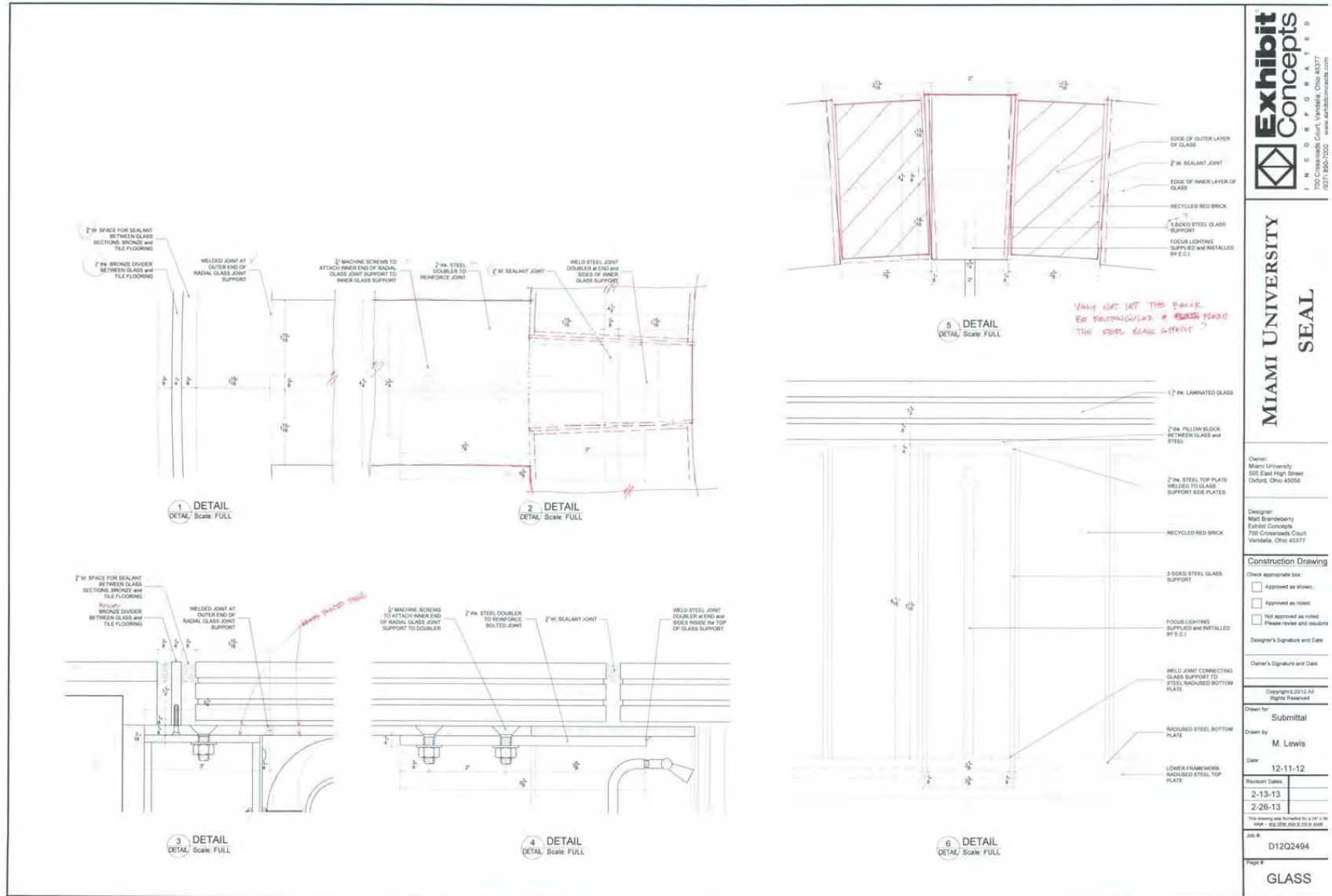

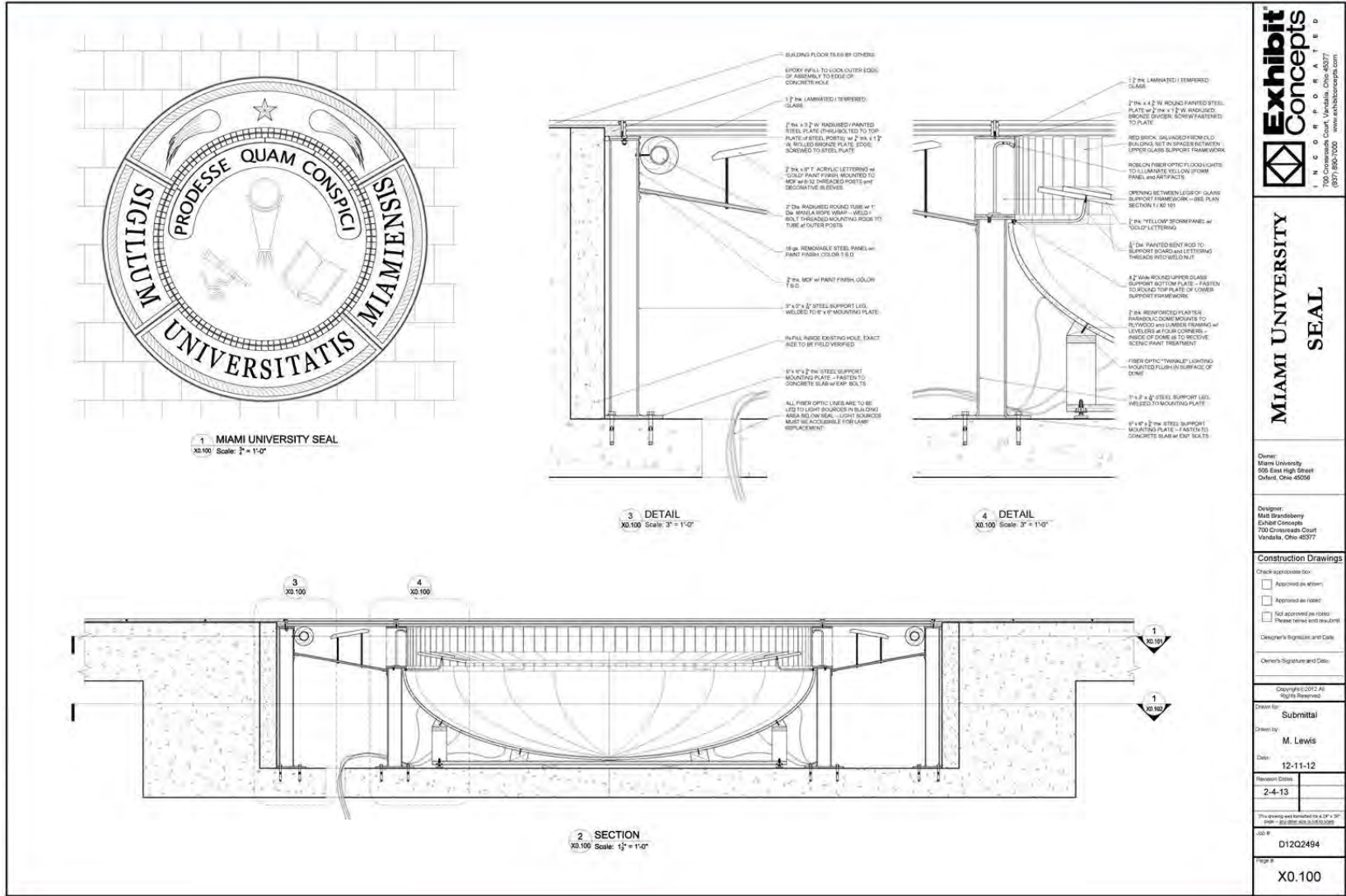

MIAMI UNIVERSITY SEAL

Owner:
Miami University
500 East High Street
Oxford, Ohio 45056

Designer:
Matt Brandenberg
2300 Crossroads
700 Crossroads Court
Wandlsville, Ohio 45377

Construction Drawings

- Check appropriate box:
- Approved as shown
 - Approved as noted
 - Not approved as noted: Please contact the Designer

Designer's Signature and Date:

Owner's Signature and Date:

Copyright © 2014 All Rights Reserved

Drawn by:
Submittal
M. Lewis

Date:
12-11-12

Revision Codes:
2-4-13

(This drawing and formative to a 24" x 36" length - @ 1/8" PER INCH UNLESS NOTED)

Sheet #
D12G2494

Page #
X0.100

v3.0



©2013 The design and elements of this presentation are the sole property of Exhibit Concepts, Inc. Duplication or use by any other party is strictly prohibited and prosecuted under copyright laws.

Miami University
Armstrong Student Center_Dimensional University Seal
02.18.13

























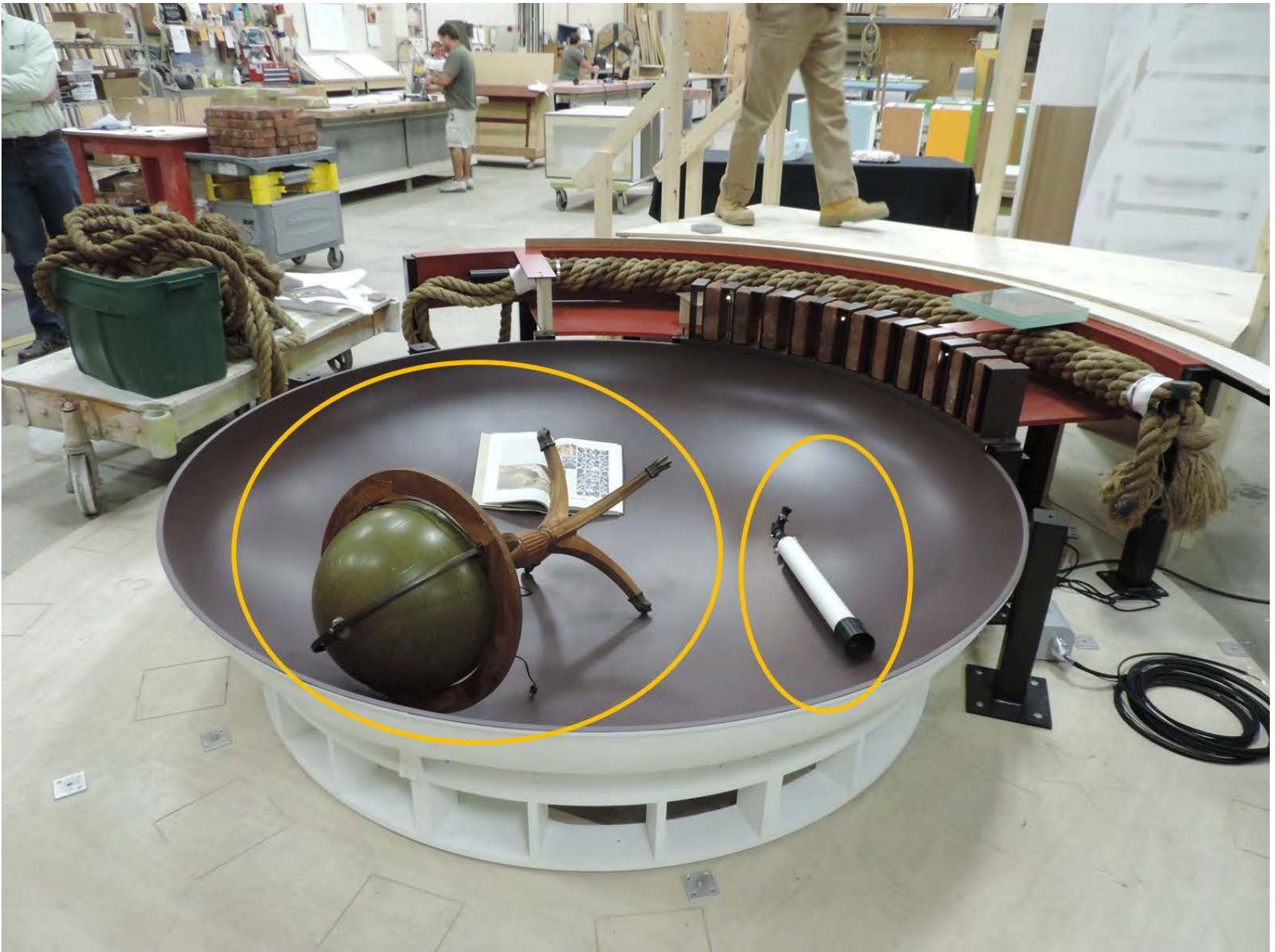



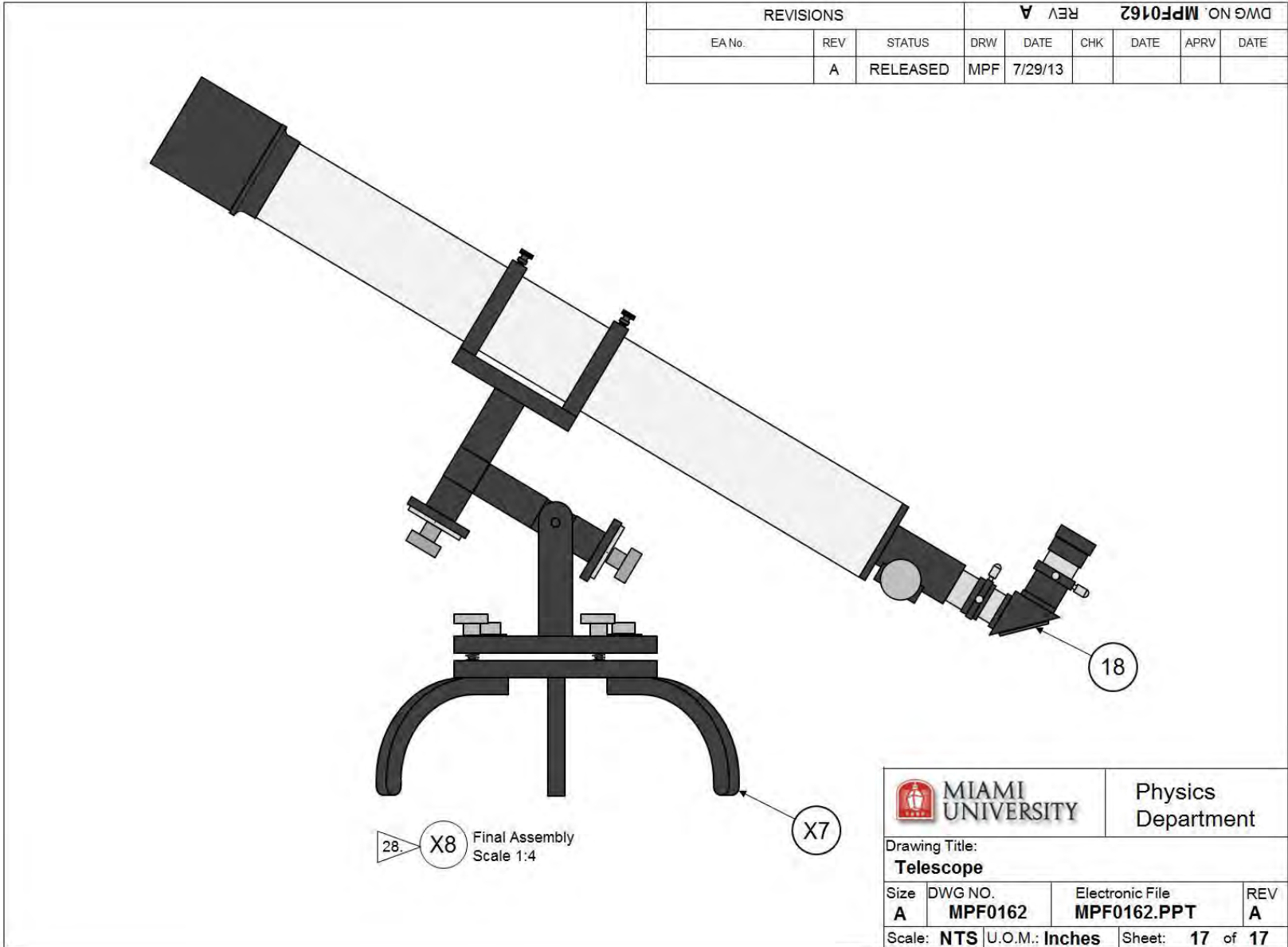

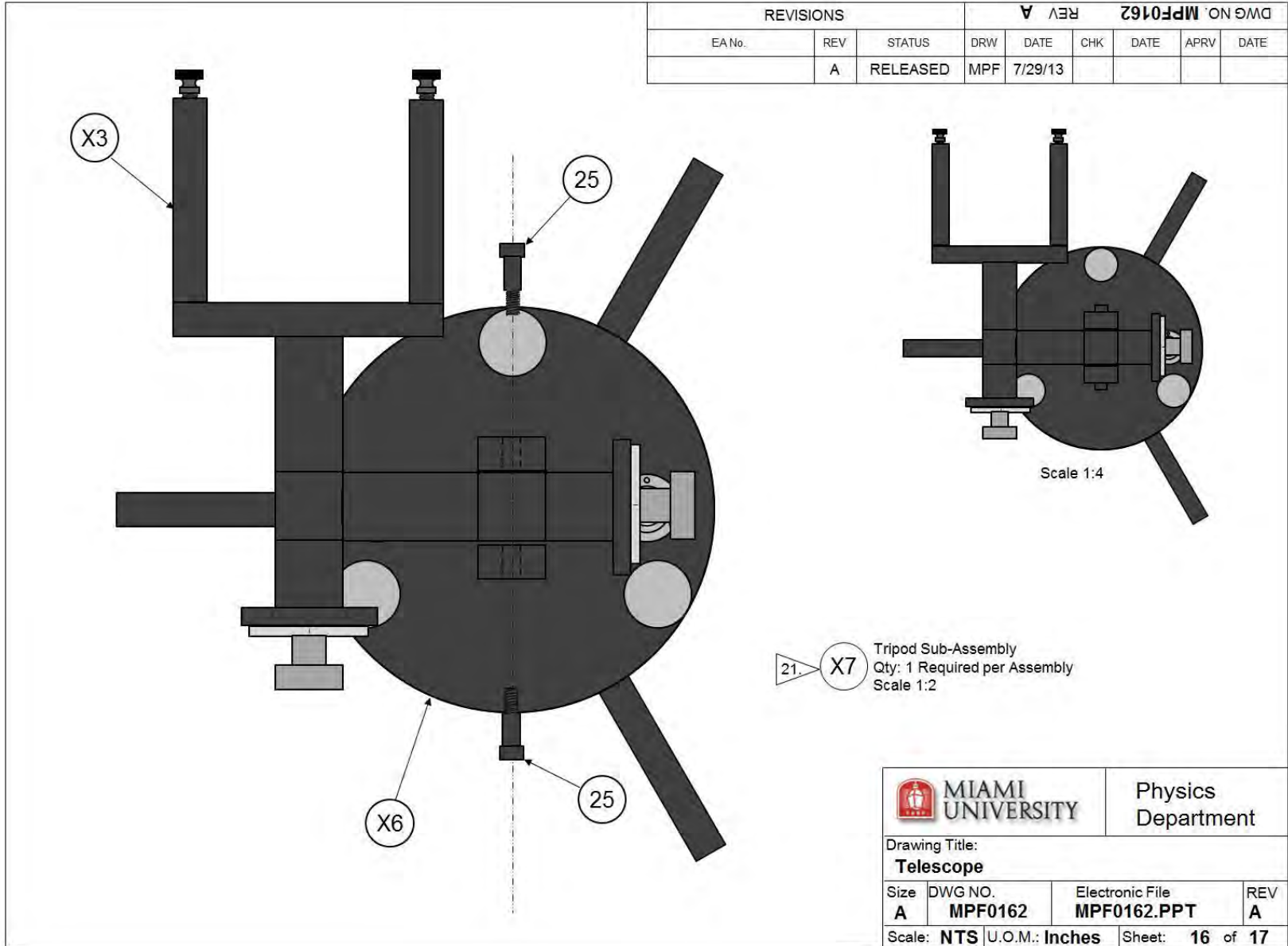

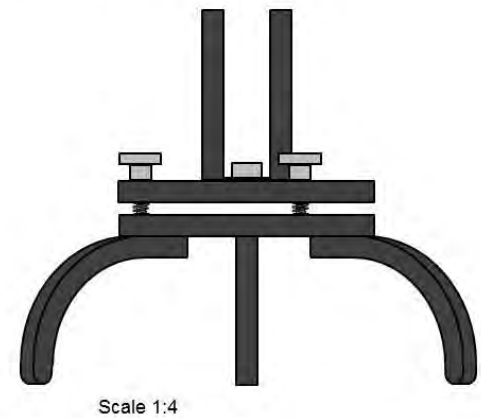
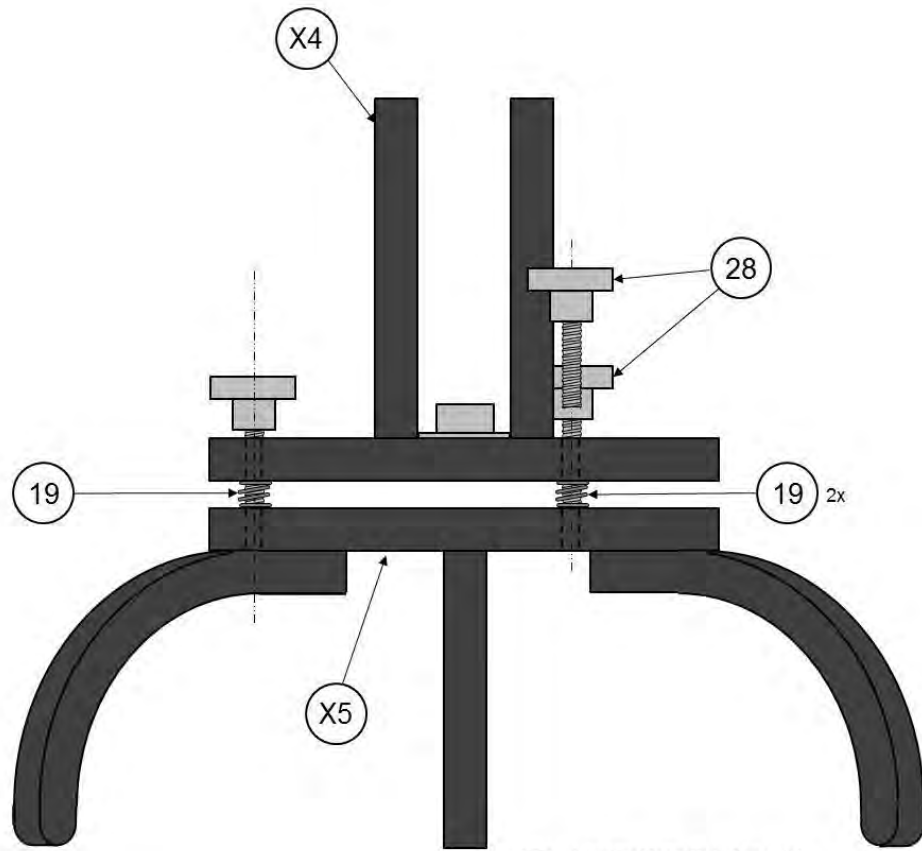

REVISIONS			DWG NO. MPF0162 REV A					
EA No.	REV	STATUS	DRW	DATE	CHK	DATE	APRV	DATE
	A	RELEASED	MPF	7/29/13				



 MIAMI UNIVERSITY		Physics Department	
Drawing Title: Telescope			
Size	DWG NO.	Electronic File	REV
A	MPF0162	MPF0162.PPT	A
Scale: NTS		U.O.M.: Inches	Sheet: 15 of 17

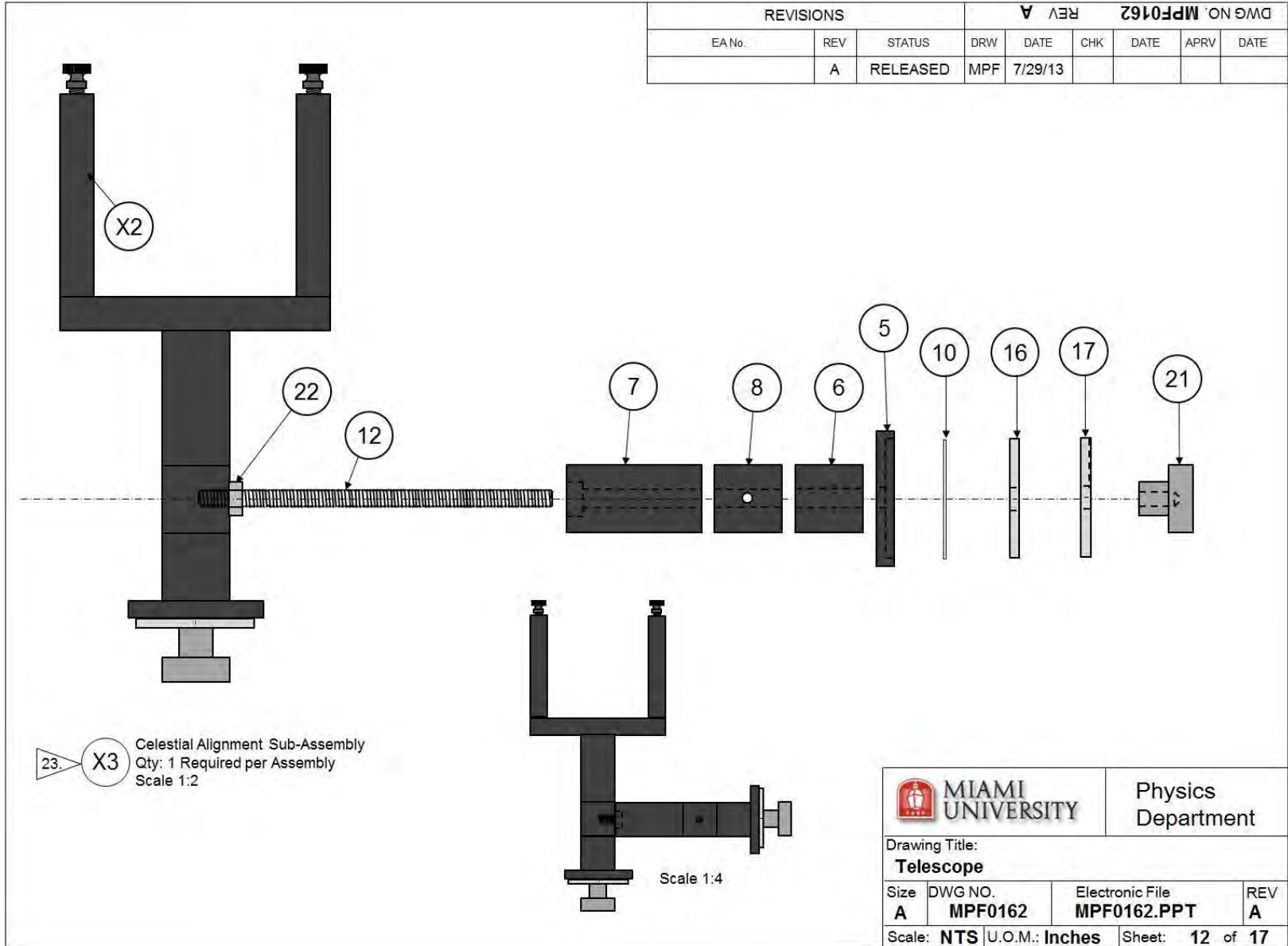















Can you provide an image of the night sky over Oxford, Ohio? Sure.



...on Feb. 17, 1809?

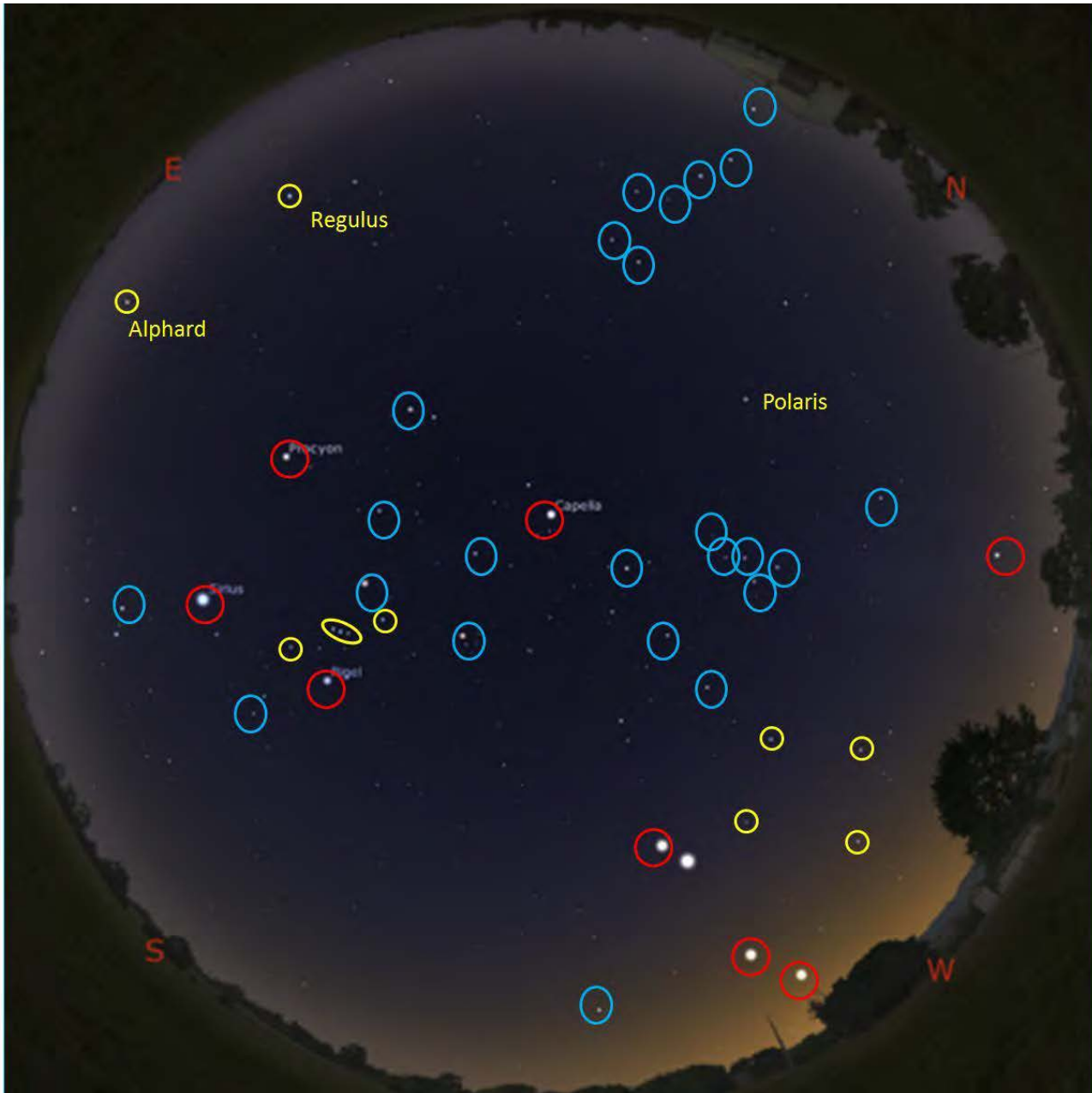

Why aren't you showing the moon Bob?
Well, I'm concerned about a big white blob over-powering the fiber twinkles.

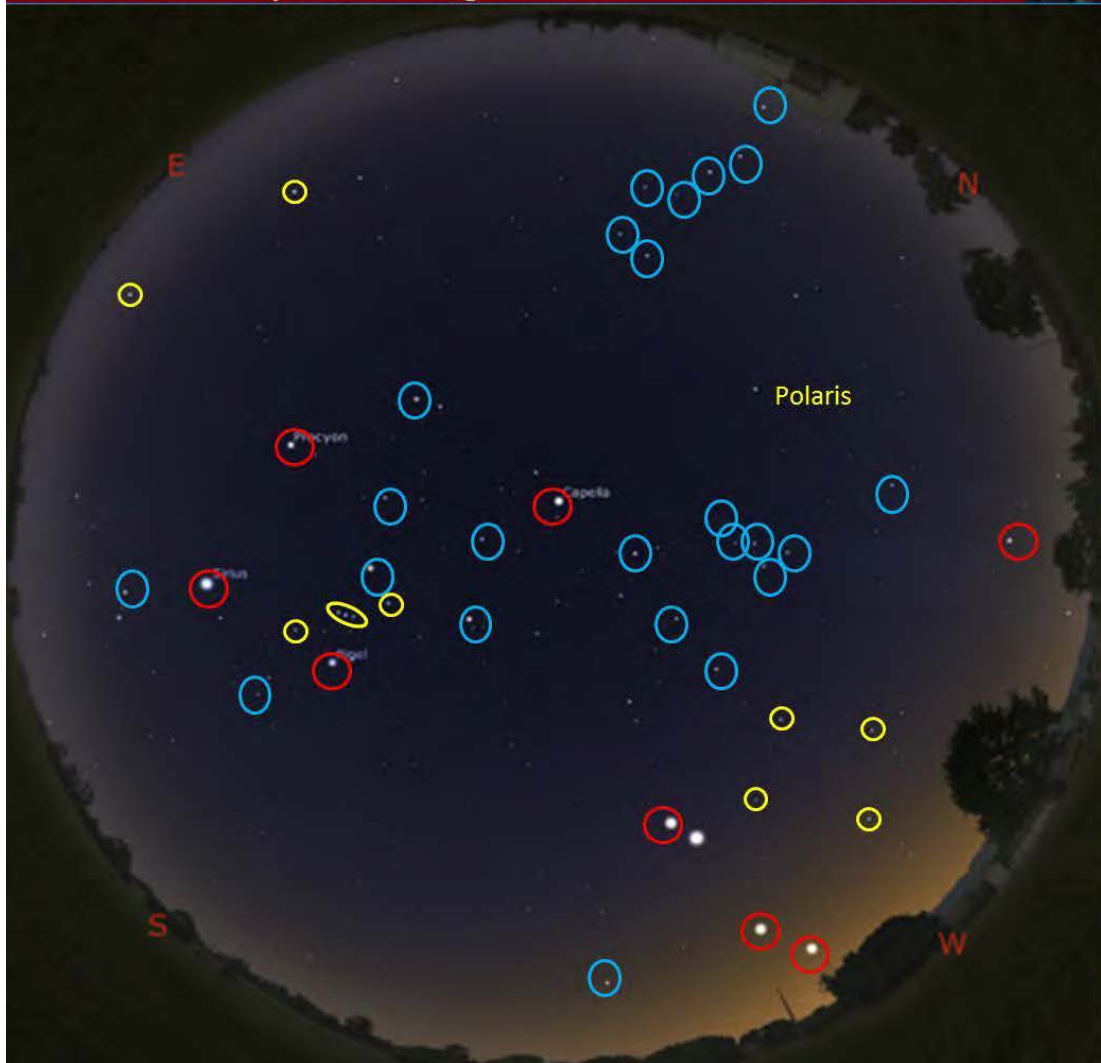

But it wasn't a full moon that night, it was this...



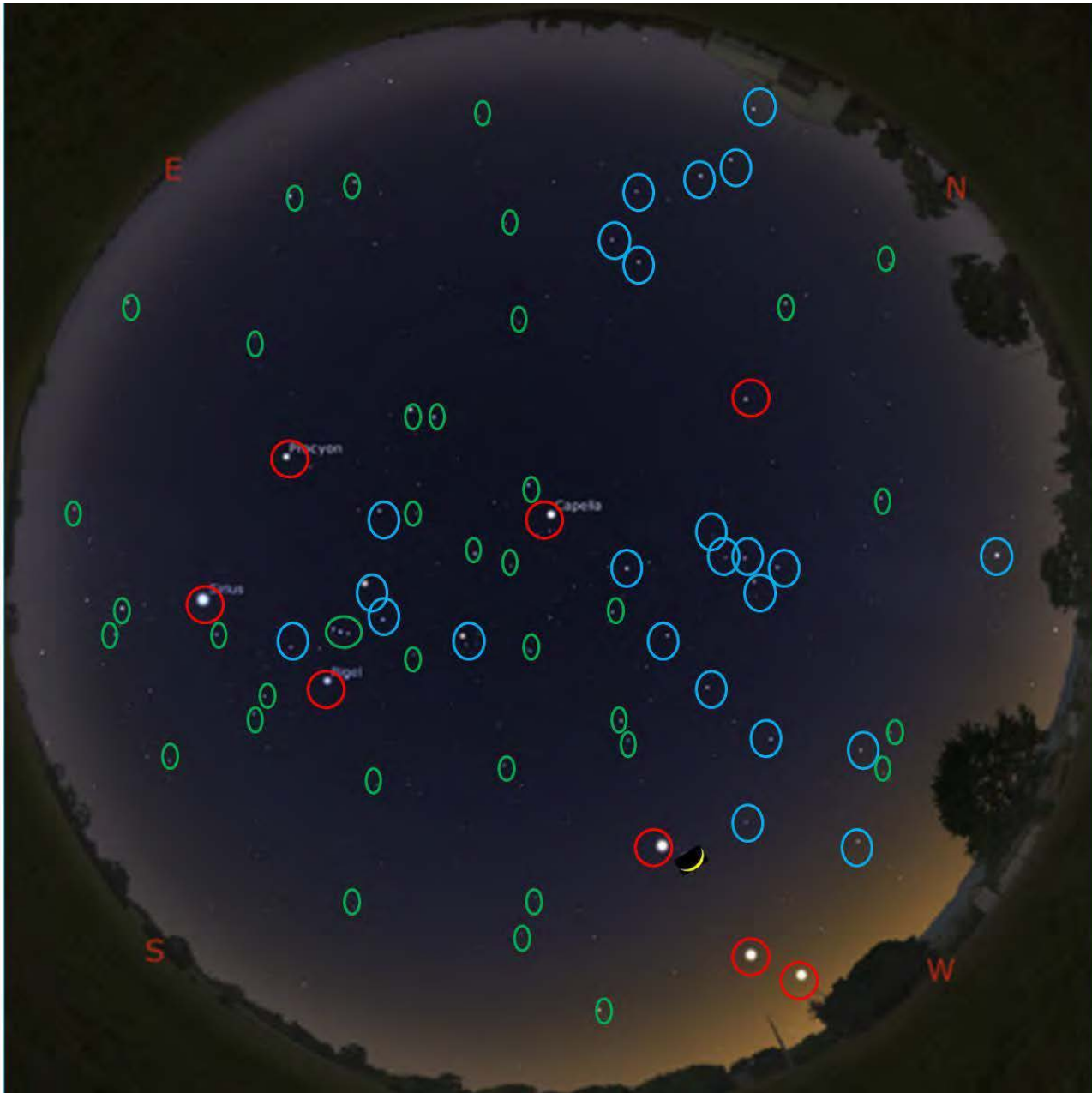





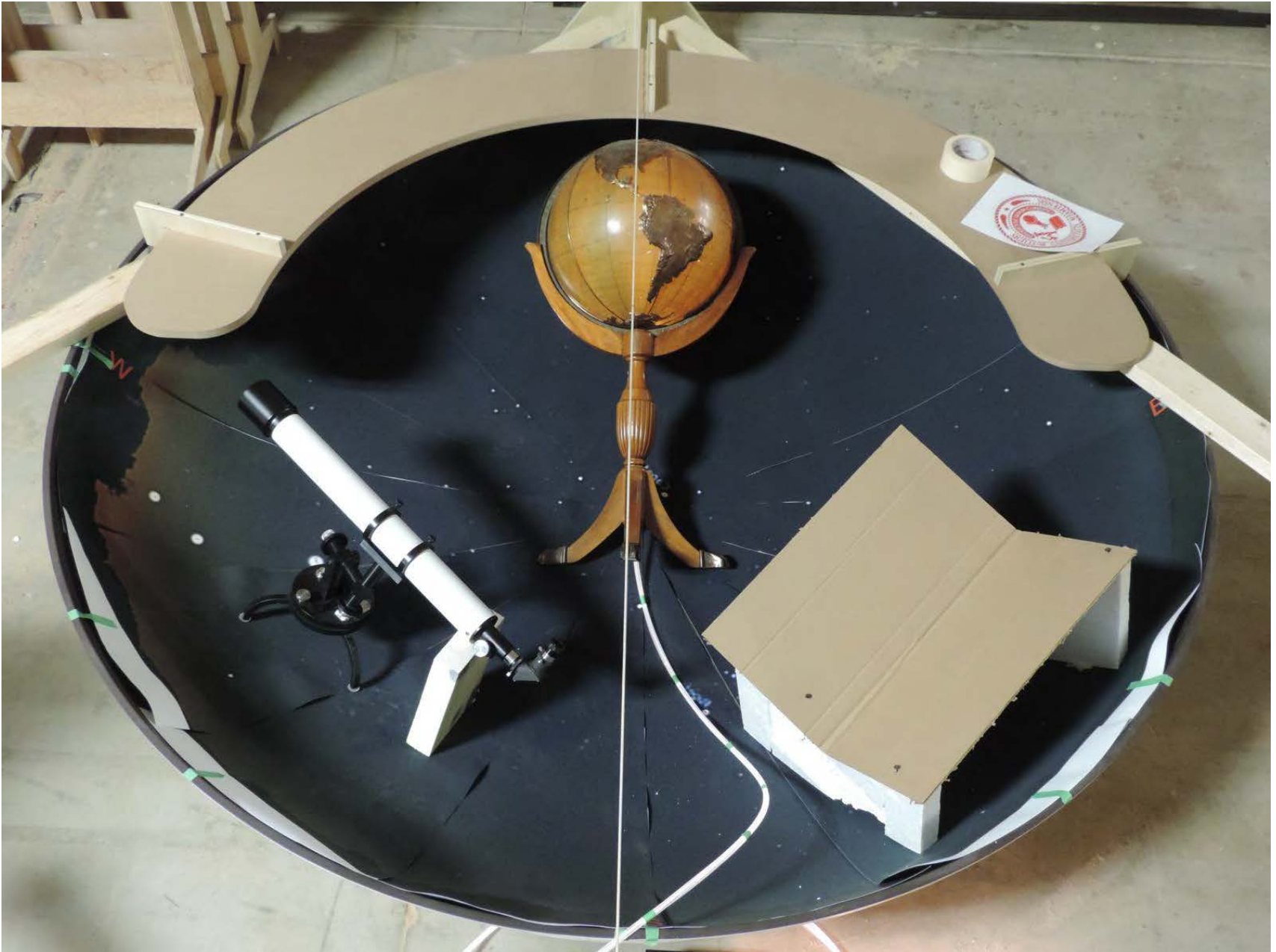

43/8" Cap Height
1/2" Acrylic 3 form letter
Polished Edge and Face

7" Cap Height
CNC prismatic routed sign letters
3/4 HDU Sign Foam
Paint to match Laminate



JOB	GRAPHIC	PRODUCTION	ECI	PARTNER	SUPPLEMENTAL	SIGN OFF
CLIENT Miami University	GRAPHIC ID 3322-01	GRAPHIC DIMENSIONS (WxH)	-	PANEL(S)	1	2nd SIDE
WORK ORDER NO. D13Q-2724	REVISION #	QUANTITY	1	BASE MATERIAL	See Spec Above	DESIGNER
PROJECT/SHOW MU Seal	GRAPHIC TYPE Custom Letters	(SUBSTRATE/APPLICATION)	1ST / 2ND	-	-	GO/PREFLIGHT
PREFLIGHT OR ARTWORK BY Tim Hosler	ARTWORK	OVERLAMINATE	None	FINISHING	None	GS/PRODUCTION
SHIP DATE	ART BY CLIENT	ADJUSTED BY ECI	None	ADDITIONAL FINISHING	None	CLIENT
8/29/13	DB/LW	LAYOUT BY ECI	None	ENG. PLAN PROVIDED		
CURRENT DATE & TIME (EST)	8/27/13	1:00p				

NOTE: Approval sheet is for general layout use only. Color & resolution may differ slightly on actual print. By agreeing to this document you are confirming that all spelling, grammar, images and color are correct.





































































MIAMI UNIVERSITY

The Armstrong Student Center:
“Bringing the Great Seal to Life”

Promotion and Tenure Recommendations

**Board of Trustees
February 7, 2014**



MIAMI UNIVERSITY

{*ERIC BACHMANN*}

*Computer Science & Software Engineering
College of Engineering & Computing
Candidate for Promotion to Professor*



*Joined Miami as associate professor in 2001
Tenured in 2008*

B.A. Mathematics & Computer Science, University of Cincinnati
M.S. and Ph.D. Computer Science, Naval Postgraduate School

*“Ideally, teaching, research, and service should all be closely related.
Developing such a relationship allows a synergy among the three.”*

{MICHAEL BRUDZINSKI}
*Geology & Environmental Earth Science
College of Arts & Science
Candidate for Promotion to Professor*



*Joined Miami in 2004
Tenured and promoted to associate professor in 2010*

*B.S. Physics & Marine Geophysics, Eckerd College
Ph.D. Geophysics, University of Illinois - Urbana Champaign*

“My overarching goal in all of the work I do is to help people better understand the physical processes happening in the Earth.”

{THELMA HORN}

*Kinesiology & Health
College of Education, Health & Society
Candidate for Promotion to Professor*



*Joined Miami in 1986
Tenured and promoted to associate professor in 1989*

B.A. Psychology, Calvin College
M.A. Physical Education, Western Michigan University
Ph.D. Psychology of Sport & Physical Activity, Michigan State University

“My approach in classroom settings is very much research based...some of my own research work has originated out of student course projects, and many of my publications have included students as co-authors.”



{*CHARLES MOUL*}

Economics

Farmer School of Business

Candidate for Tenure & Promotion to Associate Professor



Joined Miami in 2008

B.A. Economics & Political Science, Miami University

Ph.D. Economics, Northwestern University

“My teaching philosophy reflects my learning philosophy, namely that we learn by doing. Using inspiration, high expectations, and whimsy, I motivate students to take advantage of such practice opportunities.”

{CHRISTIN SCHILLINGER}

Music

College of Creative Arts

Candidate for Tenure & Promotion to Associate Professor

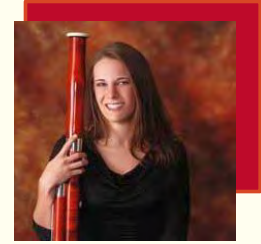

Joined Miami in 2009

Bachelor of Music – Performance & Theory, Northwestern University

Master of Music – Performance, Michigan State University

D.M.A. – Performance, Arizona State University

“I approach teaching bassoon as an apprenticeship. My experiences become my students’ [experiences].”

{ALANA VAN GUNDY}

*Political Science – College of Arts & Science
Justice & Community Studies
College of Professional Studies & Applied Sciences
Candidate for Tenure & Promotion to Associate Professor*



*Joined Miami in 2004 as adjunct and visiting faculty
Appointed as an assistant professor in 2008*

B.A. Criminal Justice & Psychology, University of Dayton
M.S. Criminal Justice, University of Cincinnati
Ph.D. Sociology, University of Cincinnati

“My motivation for my teaching, scholarship, and service stems from an over-arching focus on equal access to education and gender-based inequality.”

{ELIAS TZOC}

University Libraries
Candidate for Continuing Contract
Promotion to Associate Librarian



Joined Miami in 2008

B.S. Information Systems Management, Galileo University - Guatemala
M.S. Information Studies, University of Texas – Austin

“My work continues to provide me with excellent opportunities to explore, evaluate, and develop innovative uses of web technology that subsequently allows us to support the research, teaching and learning mission of Miami University.”

{ Candidates for Promotion & Tenure }

Promotion to Professor

Eric Bachmann
Samir Bali
Susan Brehm
Michael Brudzinski
Devon DelVecchio
Melany Fisk
Gerald Granderson
Suzanne Harper
Yvette Harris
Thelma Horn
Elizabeth Howard
Raúl Ianes
Joseph Johnson
Lei Kerr
Glenn Muschert
Marie Elise Radina
Amit Shukla
David Tierney
James Tobin

Tenure and Promotion to Associate Professor

Champike Attanayake
Annette Bollmann
John Bowblis
Dana Cox
Carole Dabney-Smith
Darrel Davis
Khalid Eid
Daniel Farley
Anne Farrell
Brooke Flinders
Kimberly Hamlin
Jae Woo Jeong

Martin Johnson
Mark Krekeler
Katherine Kivalanka
Charles Moul
Nirmala Naresh
Leighton Peterson
Paul Schaefer
Christin Schillinger
Monica Schneider
Amy Summerville
Alana Van Gundy

Continuing Contract and Promotion to Associate Librarian

Katie Davis
Jason Michel
Lindsay Miller
Masha Stepanova
Elias Tzoc

Promotion to Principal Librarian

Susan Hurst
Jenny Presnell

Promotion and Tenure Recommendations

**Board of Trustees
February 7, 2014**



MIAMI UNIVERSITY



BOARD OF TRUSTEES
ROUBUSH HALL ROOM 212
OXFORD, OHIO 45056
(513) 529-6225 MAIN
(513) 529-3911 FAX
WWW.MIAMIOH.EDU

February 7, 2014
Finance and Audit

RESOLUTION R2014-26

WHEREAS, the East Quad Renovation plan includes the renovation of five existing residence halls, one dining hall and related infrastructure improvements; and

WHEREAS, Miami University has determined that the cost of the project can be reduced through a single Design Build project delivery method; and

WHEREAS, the Board of Trustees previously approved a budget not to exceed \$5,050,000 in contracts for the preconstruction phase of the project including the planning, design, cost estimating, and other services necessary to prepare the Guaranteed Maximum Price (GMP); and

WHEREAS, Miami University has identified bond funds in the amount of \$88,280,000 to execute the construction of the East Quad Renovation project; and

WHEREAS, the East Quad Renovation project represents the largest renovation project to date for the Long Range Housing Master Plan; and

WHEREAS, the Design Build Guaranteed Maximum Price (GMP) is to be received in February 2014;

NOW, THEREFORE, BE IT RESOLVED: that the Board of Trustees authorizes the Vice President for Finance and Business Services and Treasurer, in accordance with all State guidelines, to proceed with the award of contracts for the East Quad Renovation project with a total project budget not to exceed \$93,330,000.

*Approved by the Board of Trustees
February 7, 2014*

A handwritten signature in black ink, appearing to read 'T. O. Pickerill II', written over a horizontal line.

T. O. Pickerill II
Secretary to the Board of Trustees

(over)

Executive Summary
for the
East Quad Renovation
February 7, 2014

This project will result in the renovation of five residence halls, one dining hall, portions of the north chiller plant and associated infrastructure. The facilities involved are Billings, Collins, Dennison, Dorsey, Erickson (dining), McBride, and Symmes Halls. Wilson Hall will also receive temporary utility work, as needed for two additional years of operation to enable the overall campus bed count to be maintained at the appropriate level. The project will be delivered using Design Build methodology to improve time from design to construction, reduce the cost of construction, and minimize the risk to the University. These residence hall renovations will include new windows, ADA accessibility improvements, new elevators, insulation of exterior walls and attics, new corridor ceilings, interior lighting and plumbing systems, installation of sprinkler systems, electrical distribution improvements, HVAC system upgrades, life safety and fire alarm system improvements, utility tie-ins, site utilities, selective additions and/or demolition of bedroom walls, and new bedroom finishes. The dining hall renovation will include new kitchen configurations and seating areas including new concepts for dine-in and take-out eating. This group of halls was selected to maintain the overall campus bed count and perform multiple renovations efficiently while minimizing the impact to the campus during construction.

Funding for this project will be local funds:

Bonds Funds:	\$92,404,000
Local Funds:	\$926,000

<u>Project Component:</u>	<u>Budget:</u>
Est. Consulting Services:	\$800,000
Est. Design Build Preconstruction Services:	\$5,850,000
 <u>Future Resolution:</u>	
Est. Construction Costs	\$73,790,000
Est. Furniture, Fixtures, and Equipment:	\$5,850,000
Est. Landscaping:	\$1,540,000
Owner's Contingency:	<u>\$5,500,000</u>
 Total:	 \$93,330,000



BOARD OF TRUSTEES
ROUEBUSH HALL ROOM 212
OXFORD, OHIO 45056
(513) 529-6225 MAIN
(513) 529-3911 FAX
WWW.MIAMIOH.EDU

February 7, 2014
Finance and Audit

RESOLUTION R2014-27

WHEREAS, the Western Campus Site Improvements and Landscape project involves restoration of grounds, improvements to pedestrian crossings, and development of walks and drives on the Western Campus in areas impacted by the execution of the Long Range Housing Master Plan projects; and

WHEREAS, Miami University has determined that the cost of these projects can be reduced by combining them into a single Construction Manager at Risk award of contract; and

WHEREAS, Miami University has solicited proposals and has identified a Construction Manager at Risk to execute the work; and

WHEREAS, the selected construction manager is already under contract on the Western Campus Residence Halls project and has offered additional cost savings to execute the Western Campus Site Improvements and Landscape project as a change order to its existing contract; and

WHEREAS, Miami University has identified local funds in the amount of \$5,870,000 for the Western Campus Site Improvements and Landscape project;

NOW, THEREFORE, BE IT RESOLVED: that the Board of Trustees hereby authorizes the Vice President for Finance and Business Services and Treasurer, in accordance with all State guidelines, to proceed with the Western Campus Site Improvements and Landscape project by executing a change order to the Western Campus Residence Halls project with a value not to exceed \$5,870,000.

*Approved by the Board of Trustees
February 7, 2014*

A handwritten signature in black ink, appearing to read 'T. O. Pickerill II', with a long horizontal flourish extending to the right.

T. O. Pickerill II
Secretary to the Board of Trustees

Executive Summary
for the
Western Campus Site Improvements and Landscape
February 7, 2014

This project will improve pedestrian flow in and around the Western Campus and restore the grounds surrounding the new Western Campus Residence Halls and Dining Hall construction sites as part of the Long Range Housing Master Plan. The project also addresses vehicular signalization, pedestrian crossings, and pedestrian sidewalks on Patterson Avenue and Spring Street in preparation for additional students residing on the Western Campus and the opening of the new Armstrong Student Center. Work will include storm water management, site grading, fire lane construction, pedestrian lighting, vehicular signalization, roadway improvements, sidewalks, and landscaping.

This project has been planned to coordinate with the completion of multiple projects on the Western Campus and annual Walks and Drives improvements. Construction Manager at Risk was selected as the project delivery method because of the importance for the University to direct the design outcomes of this type of project. An architect of record was selected many months ago and the design has been advanced in preparation for the selection of a CMR. All State guidelines for advertisement and selection of a CMR have been followed. Whiting Turner, the Design Builder for the Western Campus Residence Halls project was the successful candidate. In their proposal, Whiting Turner offered additional savings to the project by incorporating the work into their existing contract through reduced overhead and CM contingency. The additional savings to the project has led to the recommendation to accomplish this work as a change order.

Funding for this project will be local funds:

Bond Funds	\$2,065,000
Local	\$3,805,000

Project Component:	Budget:
Est. Consulting Services:	\$600,000
Est. Construction:	\$4,557,000
Est. Furniture, Fixtures and Equipment:	\$183,000
Owner's Contingency:	\$530,000
 Total:	 \$5,870,000



BOARD OF TRUSTEES
ROUDEBUSH HALL ROOM 212
OXFORD, OHIO 45056
(513) 529-6225 MAIN
(513) 529-3911 FAX
WWW.MIAMIOH.EDU

February 7, 2014
Finance and Audit

RESOLUTION R2014-28

WHEREAS, it has been almost twenty years since Peabody Hall was last renovated and a modest investment in this facility will allow it to continue to be operated for the benefit of student residents and certain academic functions; and

WHEREAS, the timing of these improvements will also allow for changes that will enable Peabody Hall to be served by the new geo-thermal plant in the future; and

WHEREAS, Miami University has determined that cost savings can be achieved by combining the projects into a single Construction Manager at Risk contract; and

WHEREAS, Miami University has identified local funds in the amount of \$1,900,000 for the Peabody Hall Renovation; and

WHEREAS, the Guaranteed Maximum Price (GMP) is to be received in March 2014; and

WHEREAS, the Board of Trustees desires to award a contract to the most responsive and responsible Construction Manager at Risk;

NOW, THEREFORE, BE IT RESOLVED: that the Board of Trustees hereby authorizes the Vice President for Finance and Business Services and Treasurer, in accordance with all State guidelines, to proceed with the award of contract for the Peabody Hall Renovation project with a total project budget not to exceed \$1,900,000.

*Approved by the Board of Trustees
February 7, 2014*

T. O. Pickerill II
Secretary to the Board of Trustees

(over)

Executive Summary
for the
Peabody Hall Renovations
February 7, 2014

This project will replace the HVAC units in the resident rooms, common areas, five classrooms, and the ground floor offices. These replacement units will allow Peabody Hall to be connected to the Western Campus geothermal loop in the future. The building chillers and their associated equipment are beyond their useful life and also will be replaced. The Resident Advisor apartment kitchen will be renovated, student rooms will be painted and equipped with energy efficient lighting and vacancy sensors, and the hallway lighting will be replaced with more energy efficient units.

Funding for this project will be local funds:

Bond Funds:	\$1,200,000
University CR&R:	\$700,000

<u>Project component:</u>	<u>Budget:</u>
Est. Consulting Services:	\$55,000
Est. Construction Costs:	\$1,650,000
Est. Furniture, Fixtures, and Equipment:	\$20,000
Owner's Contingency:	<u>\$175,000</u>
 Total:	 \$1,900,000



BOARD OF TRUSTEES
ROUDEBUSH HALL ROOM 212
OXFORD, OHIO 45056
(513) 529-6225 MAIN
(513) 529-3911 FAX
WWW.MIAMIOH.EDU

February 7, 2014
Finance and Audit

RESOLUTION R2014-29

WHEREAS, the summer improvement plan for residence and dining halls will affect thirteen residence halls better ensuring these facilities are adequately maintained and able to meet the needs of students until the buildings are renovated later in the Housing and Dining Master Plan; and

WHEREAS, the summer improvement plan will also make minor improvements to the Recreational Sports Center which has now been in operation for twenty years; and

WHEREAS, Miami University has determined that the cost of the project can be reduced by combining these projects into a Single Prime project delivery method; and

WHEREAS, Miami University has identified local funds in the amount of \$1,500,000 for the project; and

WHEREAS, the \$1.5 million budget includes a cost of construction estimate of approximately \$1.1 million; and

WHEREAS, the State of Ohio allows the award of contracts up to 110% of the construction estimate necessitating a bid variation contingency of \$110,000 in addition to the \$1.1 million construction budget; and

WHEREAS, the design is being completed and receipt of bids is planned for April 2014; and

NOW, THEREFORE, BE IT RESOLVED: that the Board of Trustees hereby authorizes the Vice President for Finance and Business Services and Treasurer, in accordance with all State guidelines, to proceed with the award of contract for the HDRBS Improvements 2014 project with a total project budget not to exceed \$1,500,000.

*Approved by the Board of Trustees
February 7, 2014*

A handwritten signature in black ink, appearing to read 'T. O. Pickerill II', written over a horizontal line.

T. O. Pickerill II
Secretary to the Board of Trustees

(over)

Executive Summary
for the
HDRBS Improvements 2014 Projects
February 7, 2014

The project will result in updates to specific areas within thirteen residence halls and the Recreational Sports Center during the summer of 2014. The facilities involved are Recreational Sports Center, Dodds, Emerson, Hamilton, Havighurst, MacCracken, McKee, Minnich, Morris, Porter, Richard, Scott, Stanton, and Tappan Halls. The upgrades are necessary to maintain these residence halls and enable them to be operated efficiently in the near term, as they are not scheduled for full renovation until the latter part of the Long Range Housing Master Plan. The project will employ the Single Prime delivery method to reduce construction costs, manage the schedule, and allow for closer oversight of the various projects. All buildings will receive new room signage, energy efficient lighting in the corridors and public areas, and new water softening systems that eliminate the need for salt. Various other mechanical improvements, paint, and flooring upgrades will also occur.

Funding for this project will be local funds:

HDRBS CR&R:	\$1,200,000
RSC CR&R	\$300,000

<u>Project component:</u>	<u>Budget:</u>
Est. Consulting Services:	\$120,000
Est. Construction Costs:	\$1,100,000
Est. Furniture, Fixtures, and Equipment:	\$80,000
Owner's Contingency:	<u>\$200,000</u>
 Total:	 \$1,500,000



BOARD OF TRUSTEES
ROUDEBUSH HALL ROOM 212
OXFORD, OHIO 45056
(513) 529-6225 MAIN
(513) 529-3911 FAX
WWW.MIAMIOH.EDU

February 7, 2014
Finance and Audit

RESOLUTION R2014-30

WHEREAS, it is anticipated that the Ohio General Assembly will appropriate funding to renovate Shideler Hall for Miami's geosciences program during the current legislative session; and

WHEREAS, Miami University, in anticipation of the appropriation, intends to complete the design, cost estimating, and preconstruction services required to develop a Guaranteed Maximum Price (GMP) for a subsequent resolution once the funding is appropriated; and

WHEREAS, the Board of Trustees desires to award a contract to the most responsive and responsible Construction Manager at Risk;

NOW, THEREFORE, BE IT RESOLVED: that the Board of Trustees authorizes the Vice President for Finance and Business Services and Treasurer, in accordance with all State guidelines, to proceed with the award of contract for the preconstruction phase of the Shideler Hall Renovation project which includes planning, design, estimating and all related preconstruction services necessary to prepare the Guaranteed Maximum Price (GMP) for a budget not to exceed \$2,500,000.

*Approved by the Board of Trustees
February 7, 2014*

A handwritten signature in black ink, appearing to read 'T. O. Pickerill II', with a horizontal line extending to the right.

T. O. Pickerill II
Secretary to the Board of Trustees

(over)

Executive Summary
For the
Shideler Hall Renovation
February 7, 2014

This project will result in the renovation of Shideler Hall for the geosciences programs that include Geology and Environmental Earth Sciences, Geography, and members of the Institute for Environmental Sustainability. As a result of this project, classroom and lab spaces will undergo major updates to reflect today's teaching and research needs and aging building systems will either be replaced or repaired. The improvements will include more energy efficient mechanical systems, new plumbing and lighting, an improved electrical distribution system, data and telecommunications improvements, updated life safety systems, and ADA upgrades.

Project Component:	Budget:	Funding Source:
Est. Consulting services:	\$2,500,000	State Funds
Est. Construction:	\$17,525,000	State Funds
Est. Furniture Fixtures, and Equipment:	\$1,000,000	State Funds
Owner's Contingency:	\$1,725,000	State Funds
 Total:	 \$22,750,000	 State Funds



BOARD OF TRUSTEES
ROUDEBUSH HALL ROOM 212
OXFORD, OHIO 45056
(513) 529-6225 MAIN
(513) 529-3911 FAX
WWW.MIAMIOH.EDU

February 7, 2014
Finance and Audit

RESOLUTION R2014-31

WHEREAS, the “tunnel top” system has been in place on the Oxford Campus for over thirty years and needs to be replaced; and

WHEREAS, a new more efficient design for the tunnel top has been developed and the deteriorated sections of the current system are being replaced in phases; and

WHEREAS, the HUB Quad Tunnel Top Replacement project involves the installation of the new tunnel top design in the area of the HUB; and

WHEREAS, Miami University has determined that the cost of the project can be reduced by employing the Single Prime project delivery method; and

WHEREAS, Miami University has identified local funds in the amount of \$1,500,000 for the HUB Quad Tunnel Top Replacement project; and

WHEREAS, the \$1.5 million budget includes a cost of construction estimate of approximately \$1.2 million; and

WHEREAS, the State of Ohio allows for the award of contracts up to 110% of the construction estimate necessitating a bid variation contingency of \$120,000 in addition to the \$1.2 million construction budget; and

WHEREAS, the design is being completed and receipt of bids is planned for April 2014; and

WHEREAS, the Board of Trustees desires to award a contract to the lowest responsive and responsible bidder;

NOW, THEREFORE, BE IT RESOLVED: that the Board of Trustees hereby authorizes the Vice President for Finance and Business Services and Treasurer, in accordance with all State guidelines, to proceed with the award of contracts for the HUB Quad Tunnel Top Replacement project with a total construction budget not to exceed \$1,500,000.

*Approved by the Board of Trustees
February 7, 2014*

T. O. Pickerill II
Secretary to the Board of Trustees

(over)

Executive Summary
for the
HUB Quad Tunnel Top Replacement
February 7, 2014

This project will remove and replace approximately 2,200 linear feet of badly deteriorated tunnel top slab within the HUB Quad. The top of the existing tunnel also acts as a sidewalk for the HUB Quad. The poor condition of the existing tunnel top/sidewalk is a trip hazard, and it cannot support the Oxford Fire Department's fire-fighting ladder trucks in case of a fire.

The new system will use a precast structural slab, waterproofing system, and topping slab to serve as the new pedestrian walkway and traffic-bearing surface. The new structural system will also be capable of supporting any emergency vehicle loads to enhance life safety and accessibility in the area of the quad. The tunnel top replacement will require minor relocations of electrical conduit for lighting and temporary bracing of the walls. In addition, the anticipated increase in elevation due to the new method will require area grading and storm water management improvements. The project will be delivered using the Single Prime General Contracting methodology.

Funding for this project will be local funds:

University Bldg. CR&R: \$1,500,000

<u>Project component:</u>	<u>Budget:</u>
Est. Professional Services:	\$145,000
Est. Construction:	\$1,200,000
Owner's Contingency:	<u>\$155,000</u>
 Total:	 \$1,500,000



BOARD OF TRUSTEES
ROUEBUSH HALL ROOM 212
OXFORD, OHIO 45056
(513) 529-6225 MAIN
(513) 529-3911 FAX
WWW.MIAMIOH.EDU

February 7, 2014
Finance and Audit

RESOLUTION R2014-32

WHEREAS, Miami University has developed a long-term plan to upgrade the antiquated 4160-volt electrical distribution system that still exists in parts of the Oxford campus today; and

WHEREAS, Miami University has identified local funds in the amount of \$1,305,000 for the Art Quad Electrical Modifications and the Center for Performing Arts (CPA) HVAC Replacement project in support of the long-term plan; and

WHEREAS, the \$1,305,000 budget includes a cost of construction estimate of approximately \$1,140,000; and

WHEREAS, the State of Ohio permits contracts to be awarded up to 110% of the construction estimate necessitating a bid variation contingency of \$114,000 in addition to the \$1,140,000 construction budget; and

WHEREAS, the receipt of bids is planned for April 2014; and

WHEREAS, the Board of Trustees desires to award a contract to the most responsive and responsible bidder;

NOW, THEREFORE, BE IT RESOLVED: that the Board of Trustees hereby authorizes the Vice President for Finance and Business Services and Treasurer, in accordance with all State guidelines, to proceed with the award of contract for the Art Quad Electrical Modifications and CPA HVAC Replacement project with a total project budget not to exceed \$1,305,000.

*Approved by the Board of Trustees
February 7, 2014*

T. O. Pickerill II
Secretary to the Board of Trustees

(over)

Executive Summary
for the
Art Quad Electric Upgrades and CPA HVAC Replacement
February 6, 2014

This electrical project is part of a long-term plan to vacate the antiquated 4160-volt electrical distribution system. The project includes a new 12.5 kV switch and upgrade for electric service to the Art Building, Center for Performing Arts (CPA), Hiestand Hall and Shriver Center. In addition, new unit substations for CPA and Shriver Center will be installed. The heating, ventilation, and air-conditioning (HVAC) portion of the project will replace two air-handlers located in the basement of CPA. The building's controls will also be upgraded as part of the work. The HVAC improvements address deferred maintenance and will enhance the energy efficiency of the building.

Funding for this project will be local funds:

UEA CR&R:	\$405,000
University CR&R:	\$900,000

<u>Project component:</u>	<u>Budget:</u>
A/E Services:	\$51,000
Est. Construction Costs (incl. Permit/Insp) Fees:	\$1,140,000
Owner's Contingency:	<u>\$114,000</u>
Total:	\$1,305,000



BOARD OF TRUSTEES
ROUDEBUSH HALL ROOM 212
OXFORD, OHIO 45056
(513) 529-6225 MAIN
(513) 529-3911 FAX
WWW.MIAMIOH.EDU

February 7, 2014
Finance and Audit

RESOLUTION R2014-33

WHEREAS, the age of some regional campus buildings make it necessary that major repairs occur to aging building systems in order for the buildings to continue to be operated; and

WHEREAS, the replacement of aging heating, air conditioning and ventilation systems in Phelps Hall will also help to lower utility costs for the Hamilton Campus; and

WHEREAS, Miami University has determined that the cost of the project can be reduced by combining the projects into a Single Prime contract; and

WHEREAS, Miami University has identified funds in the amount of \$1,100,000 for the Hamilton Campus Phelps Hall HVAC Improvements, including \$555,100 appropriated by the State of Ohio; and

WHEREAS, the \$1,100,000 budget includes a cost of construction estimate of approximately \$907,000; and

WHEREAS, the State of Ohio permits contracts to be awarded up to 110% of the construction estimate necessitating a bid variation contingency of \$90,700 in addition to the \$907,000 construction budget; and

WHEREAS, the receipt of bids is planned for March 2014; and

WHEREAS, the Board of Trustees desires to award a contract to the most responsive and responsible bidder;

NOW, THEREFORE, BE IT RESOLVED: that the Board of Trustees hereby authorizes the Vice President for Finance and Business Services and Treasurer, in accordance with all State guidelines, to proceed with the award of contract for the Hamilton Campus Phelps Hall HVAC Improvements project with a total project budget not to exceed \$1,100,000.

*Approved by the Board of Trustees
February 7, 2014*

T. O. Pickerill II
Secretary to the Board of Trustees

(over)

Executive Summary
For the
Hamilton Campus Phelps Hall HVAC Improvements
February 7, 2014

This project will replace the existing pneumatic controlled Variable Air Volume ventilation boxes and pneumatic operated HVAC components with electronically controlled (DDC) devices including occupancy sensors for ventilation and lighting control. Fire suppression will be installed in both Phelps and the adjacent Parrish Auditorium. Suspended ceiling tiles will be removed and replaced. New energy efficient lighting will also be installed. The project includes reconfiguring office space in Room 101 and incorporating Room 103 (computer lab relocated to upper floor) into a new office suite in support of campus programming needs, specifically the new Criminal Justice Program.

Funding for this project will be local funds:

State:	\$555,100
Local:	\$544,900

<u>Project component:</u>	<u>Budget:</u>
A/E Services:	\$100,000
Est. Construction Costs (including Permit/Inspection) Fees:	\$907,000
Owner's Contingency:	<u>\$93,000</u>
Total:	\$1,100,000



BOARD OF TRUSTEES
ROUDEBUSH HALL ROOM 212
OXFORD, OHIO 45056
(513) 529-6225 MAIN
(513) 529-3911 FAX
WWW.MIAMIOH.EDU

February 7, 2014
Finance and Audit

RESOLUTION R2014-34

WHEREAS, Miami University has received gifts totaling \$1.5 million and pledges totaling \$1.5 million for constructing a baseball support facility as part of the Hayden Park complex; and

WHEREAS, Hayden Park Addition – Baseball Support Facility involves construction of dedicated locker rooms, coaches' offices, and support space on the third base side of Hayden Park; and

WHEREAS, the receipt of proposals is planned for April 2014; and

WHEREAS, the Board of Trustees desires to award a contract to the most responsive and responsible Construction Manager at Risk;

NOW, THEREFORE, BE IT RESOLVED: that the Board of Trustees hereby authorizes the Vice President for Finance and Business Services and Treasurer, in accordance with all State guidelines, to proceed with the award of contract for the Hayden Park Addition – Baseball Support Facility Project with a total budget not to exceed \$3,000,000.

*Approved by the Board of Trustees
February 7, 2014*

A handwritten signature in black ink, appearing to read 'T. O. Pickerill II', with a long horizontal flourish extending to the right.

T. O. Pickerill II
Secretary to the Board of Trustees

(over)

Executive Summary
For the
Hayden Park Addition – Baseball Support Facility
February 7, 2014

This project will result in an additional facility being constructed, down the third base line between the home team dugout and the indoor batting cages. This facility will include team locker rooms, coaches' offices, an equipment room and related support spaces. The facility will also support relocating the varsity baseball program from Withrow Court and further reduces the University's dependency on Withrow Court. As discussed in the December 2013 Finance and Audit Committee meeting, the project will require that the cost of financing the remaining pledges be foregone.

Funding for this project will be from gift funds:

Project Component:	Budget:	Funding Source:
Est. Consulting services:	\$205,000	Gift Funds/Local Funds
Est. Construction:	\$2,200,000	Gift Funds/Local Funds
Est. Furniture, Fixtures, and Equipment:	\$395,000	Gift Funds/Local Funds
Owner's Contingency:	\$200,000	Gift Funds/Local Funds
 Total:	 \$3,000,000	 Gift Funds/Local Funds



BOARD OF TRUSTEES
ROUDEBUSH HALL ROOM 212
OXFORD, OHIO 45056
(513) 529-6225 MAIN
(513) 529-3911 FAX
WWW.MIAMIOH.EDU

RESOLUTION R-2014-36

PROVIDING FOR THE AUTHORIZATION, ISSUANCE AND SALE OF NOT TO EXCEED \$200,000,000 OF GENERAL RECEIPTS REVENUE AND REFUNDING BONDS, SERIES 2014, OF MIAMI UNIVERSITY, APPROVING A SIXTH SUPPLEMENTAL TRUST AGREEMENT AND AUTHORIZING THE FISCAL OFFICER TO TAKE CERTAIN ACTIONS.

WHEREAS, Resolution 2004-8 adopted by this Board on September 26, 2003 (the “General Bond Resolution”), and the Amended and Restated Trust Agreement dated as of October 1, 2003, as amended, by and between the University and The Bank of New York Mellon Trust Company, N.A., as trustee (the “Trust Agreement”) provide for the issuance from time to time of General Receipts Revenue Bonds of the University, with each issuance to be authorized by a Series Resolution adopted by the Board; and

WHEREAS, the General Bond Resolution was adopted and the Trust Agreement was authorized by the Board pursuant to the Act which authorizes the University to issue its Bonds to pay costs of certain capital facilities, defined as “auxiliary facilities,” “education facilities” and “housing and dining facilities” in Section 3345.12 of the Revised Code and called “University Facilities” in the General Bond Resolution and in this Resolution; and

WHEREAS, the University has determined, and hereby confirms, that it is necessary and appropriate to issue its General Receipts Bonds to fund (i) renovation and construction of housing facilities, dining facilities and other auxiliary buildings and related improvements including, but not limited to, Brandon Hall, Flower Hall, Hahne Hall, Hepburn Hall, Martin Dining Hall, Clawson Hall, Ogden Hall, Bell Tower Place, Swing Hall, Wells Hall, Hamilton Hall and the Shriver Center, all of which are located on the Oxford campus; (ii) infrastructure upgrades and improvements on the Oxford campus including, but not limited to, certain upgrades and improvements on North Quad; (iii) other eligible capital projects approved by the Board; and (iv) payment of a portion of the costs associated with such issuance (the above-listed projects are collectively referred to as the “Series 2014 University Facilities Project” or “Project”); and

WHEREAS, the University has determined that it is advantageous from time to time to refund certain outstanding obligations of the University including all or a portion of the Series 2005 General Receipts and Refunding Bonds (the “Series 2005 Bonds”); and

WHEREAS, for the above purposes, the University has determined to issue not to exceed \$200,000,000 in aggregate principal amount of General Receipts Revenue and Refunding Bonds (the “Series 2014 Bonds”) to pay a portion of the costs of the Project, including the reimbursement to the University of moneys advanced to finance the cost of University Facilities in anticipation of being reimbursed from the proceeds of such Series 2014 Bonds, and including the refunding of the Series 2005 Bonds; and

WHEREAS, the Board determines that it is in the best interest of the University to provide for maximum flexibility in structuring the Series 2014 Bonds to achieve maximum cost savings, and therefore, has provided that certain terms of the Series 2014 Bonds shall be determined in the Certificate of Award authorized pursuant to Section 5 hereof (the "Certificate of Award");

NOW, THEREFORE, BE IT RESOLVED BY THE BOARD OF TRUSTEES OF MIAMI UNIVERSITY, as follows:

Section 1. Definitions and Interpretations. Where used in this Resolution, in the Sixth Supplemental Trust Agreement and in the Certificate of Award, and in addition to words and terms defined elsewhere in this Resolution (including its preambles), the Sixth Supplemental Trust Agreement, the General Bond Resolution or the Trust Agreement, the following terms shall have the following meanings:

"Act" means Sections 3345.11 and 3345.12 of the Ohio Revised Code.

"Annual Bond Service Charge" for any Fiscal Year (as defined in the Trust Agreement) means, in connection with the Series 2014 Bonds, an amount equal to the scheduled principal and interest due on the Series 2014 Bonds in that Fiscal Year.

"Bond Purchase Agreement" means the Bond Purchase Agreement between the Original Purchaser and the University to be dated as of its date of execution.

"Bond Year" means the annual period relevant to the application of Section 148 of the Code to the Series 2014 Bonds.

"Certificate of Award" means the Certificate of Award authorized by Section 5 hereof.

"Code" means the Internal Revenue Code of 1986, as amended, the regulations (whether proposed, temporary or final) under that Code or the statutory predecessor of that Code, and any amendments of, or successor provisions to, the foregoing and any official rulings, announcements, notices, procedures and judicial determinations regarding any of the foregoing, all as and to the extent applicable. Unless otherwise indicated, reference to a section of the Code includes that section and such applicable regulations, rulings, announcements, notices, procedures and determinations pertinent to that section.

"Computation Date" means:

- (i) (A) the last day of each Bond Year while the Series 2014 Bonds are outstanding, and (B) the date on which the last Series 2014 Bonds are retired, or
- (ii) such other date or dates elected by the University as may be permitted under the Code for computation of the Rebate Amount.

"Debt Service" means principal of and interest and any redemption premium on the Series 2014 Bonds.

“*Delivery Date*” means the date on which the Series 2014 Bonds are delivered to the Original Purchaser in exchange for payment.

“*Escrow Deposit Agreement*” means the Escrow Deposit Agreement between the University and the Escrow Trustee authorized pursuant to this Resolution, prepared in connection with the refunding of the Series 2005 Bonds.

“*Escrow Trustee*” means the Trustee acting as escrow trustee with respect to the defeasance of certain of the Series 2005 Bonds.

“*Excess Earnings*” means, as of each Computation Date, an amount determined in accordance with Section 148(f) of the Code equal to the sum of (i) plus (ii) where:

(i) is the excess of:

(a) the aggregate amount earned from the Issuance Date on all Nonpurpose Investments in which Gross Proceeds are invested (other than investments attributable to an excess described in this clause (i)), taking into account any gain or loss on the disposition of Nonpurpose Investments, over

(b) the amount which would have been earned if the amount of the Gross Proceeds invested in those Nonpurpose Investments (other than investments attributable to an excess described in this clause (i)) had been invested at a rate equal to the Yield on the Series 2014 Bonds; and

(ii) is any income attributable to the excess described in clause (i), taking into account any gain or loss on the disposition of investments.

“*Fiscal Officer*” means the Vice President for Finance and Business Services and Treasurer of Miami University.

“*General Counsel*” means the chief legal officer of the University.

“*Gross Proceeds*” means (i) Proceeds, (ii) Replacement Proceeds, and (iii) any other money, investments, securities, obligations or other assets that constitute “gross proceeds” for purposes of Section 148(f) of the Code as applied to the Series 2014 Bonds, all until spent.

“*Interest Payment Dates*” means the first day of March and September in each year, commencing September 1, 2014 or such other date as may be provided in the Certificate of Award.

“*Investment Proceeds*” means any amounts actually or constructively received from investing Original Proceeds.

“*Investment Property*” means (i) “investment property” as defined in Section 148(b)(2) of the Code, including any security (within the meaning of Section 165(g)(2)(A) or (B)) of the Code, any obligation, any annuity contract, and any investment-type property. Investment Property does not include a Tax-Exempt Bond, except a Tax-Exempt Bond which is a “specified

private activity bond” as defined in Section 57(a)(5)(C) of the Code, the interest on which is an item of tax preference for purposes of the alternative minimum tax imposed on individuals and corporations, or (ii) qualified exempt investment, that is, a United States Treasury obligation - Demand Deposit State and Local Government Series.

“*Issuance Date*” means the date of physical delivery of the Series 2014 Bonds by the University in exchange for the purchase price of the Series 2014 Bonds.

“*Issue Price*” means the aggregate of the initial offering prices (including accrued interest and original issue discount and/or premium, if any) at which each maturity of the Series 2014 Bonds was offered to the public (excluding bond houses, brokers and other intermediaries) and at which price or prices a substantial amount of each maturity of the Series 2014 Bonds was sold to the public (other than to bond houses, brokers and other intermediaries).

“*Letter of Instructions*” means a letter addressed to the Trustee dated the Issuance Date and signed by the Fiscal Officer.

“*Nonpurpose Investments*” shall have the meaning ascribed to such term in Section 148 of the Code and shall mean any investment other than a Purpose Investment (which is an investment acquired in order to carry out the governmental purpose of the Series 2014 Bonds).

“*Original Proceeds*” means Sales Proceeds and Investment Proceeds.

“*Original Purchaser*” means the investment banking firm selected by the Fiscal Officer.

“*Proceeds*” means any Original Proceeds from the sale of the Series 2014 Bonds and any Transferred Proceeds, as defined in Regulations 1.148-8(d)(2).

“*Purpose Investment*” means an investment acquired in order to carry out the governmental purpose of the Series 2014 Bonds, which is (i) renovation and construction of housing and dining facilities and related infrastructure upgrades; and (ii) payment of a portion of the costs associated with such issuance.

“*Rebate Amount*” means the amount of Excess Earnings (excluding any amount earned on a Bona Fide Debt Service Fund) computed as of the most recent prior Computation Date in accordance with the requirements of Section 148(f) of the Code.

“*Refunding Bonds*” means a portion of the Series 2014 Bonds, the proceeds of which will be utilized to refund a portion of the University’s Series 2005 Bonds.

“*Sales Proceeds*” means the portion of the Issue Price received by the University upon the sale of the Series 2014 Bonds (net of any underwriter’s discount withheld from the Issue Price).

“*Securities Depository*” means initially The Depository Trust Company (a limited purpose trust company), New York, New York.

“*Series 2005 Bonds*” means the University’s General Receipts Revenue and Refunding Bonds, Series 2005.

“*Series 2014 Bonds*” means the series of General Receipts Revenue and Refunding Bonds authorized by this Resolution and issued pursuant to this Resolution and the Certificate of Award.

“*Series 2014 University Facilities Project*” or “*Project*” means the University has determined, and hereby confirms, that it is necessary and appropriate to issue its General Receipts Bonds to fund (i) renovation and construction of housing facilities, dining facilities and other auxiliary buildings and related improvements including, but not limited to, Brandon Hall, Flower Hall, Hahne Hall, Hepburn Hall, Martin Dining Hall, Clawson Hall, Ogden Hall, Bell Tower Place, Swing Hall, Wells Hall, Hamilton Hall and the Shriver Center, all of which are located on the Oxford campus; (ii) infrastructure upgrades and improvements on the Oxford campus including, but not limited to, certain upgrades and improvements on North Quad; (iii) other eligible capital projects approved by the University; and (iv) payment of a portion of the costs associated with such issuance (the above-listed projects are collectively referred to as the “*Series 2014 University Facilities Project*” or “*Project*”).

“*Series 2014 Resolution*” or “*Resolution*” means this Resolution authorizing the issuance and sale of the Series 2014 Bonds.

“*Sinking Fund Proceeds*” means amounts (including any investment income) treated as Proceeds of the Series 2014 Bonds under the Code because they are accumulated in a sinking fund to pay Debt Service within the meaning of Treasury Regulations §1.103-13(g), but excluding amounts withdrawn therefrom.

“*Sixth Supplemental Trust Agreement*” means the Sixth Supplemental Trust Agreement between the University and the Trustee, authorized pursuant to Section 7.01 of the Trust Agreement and this Resolution.

“*Special Record Date*” means the date established by the Trustee in connection with the payment of any overdue interest on any Bond pursuant to Section 4(e)(ii) of this Resolution.

“*Tax-Exempt Bond*” means any obligation, or issue of obligations, the interest on which is, or is intended to be, excluded from gross income for federal income tax purposes within the meaning of Section 150 of the Code, and includes any investment treated as a “tax-exempt bond” for the applicable purpose of Section 148 of the Code.

“*Transferred Proceeds*” means any proceeds of a prior issue that become Proceeds of the Series 2014 Bonds.

“*Trustee*” means The Bank of New York Mellon Trust Company, N.A., as successor to J.P. Morgan Trust Company, National Association as trustee under the Trust Agreement.

“*2014 University Facilities Costs of Issuance Fund*” or “*2014 Costs of Issuance Fund*” means the fund established by the University used to pay certain costs related to the issuance of obligations for the Project that constitute “costs of facilities” as defined in the Act.

“2014 University Facilities Project Fund” or “2014 Project Fund” means the fund established by the University used to pay costs of the Project that constitute “costs of facilities” as defined in the Act.

“Yield” has the meaning assigned to it for purposes of Section 148 of the Code, and means that discount rate that, when used in computing the present value of all payments of principal and interest to be paid on an obligation, computed on the basis of a 360-day year and semiannual compounding, produces an amount equal to (i) the Issue Price in the case of the Series 2014 Bonds, or (ii) the purchase price for Yield purposes in the case of Investment Property. The Yield on Investment Property in which Proceeds of the Series 2014 Bonds are invested is computed on a basis consistent with the computation of Yield on the Series 2014 Bonds.

The terms “state or local bonds, governmental unit”, “loan”, “private business use”, “net proceeds” and other terms relating to Code provisions used but not defined in this Section 12 shall have the meanings given to them for purposes of Sections 103, 141, 148 and 150 of the Code unless the context indicates another meaning. References in this section to Sections are, unless otherwise indicated, references to Code sections.

Unless the context shall otherwise indicate, words importing the singular number shall include the plural number, and vice versa, and the terms “hereof,” “herein,” “hereby,” “hereto,” “hereunder,” and similar terms, mean this Resolution and the Sixth Supplemental Trust Agreement. References to sections, unless otherwise stated, are to sections of this Resolution.

Section 2. Authority. This Resolution is adopted pursuant to the General Bond Resolution, the Trust Agreement and the Act.

Section 3. Authorization, Designation and Purpose of Series 2014 Bonds. It is hereby declared to be necessary to, and the University shall, issue, sell and deliver, as provided and authorized by this Resolution, General Receipts Bonds of the University, which shall be designated “Miami University General Receipts Revenue and Refunding Bonds, Series 2014” in the maximum original aggregate principal amount of not to exceed \$200,000,000 (the actual original aggregate principal amount to be as provided by the Certificate of Award), for the purpose of paying a portion of the costs of the University Facilities that comprise the Series 2014 University Facilities Project, refunding a portion of the Series 2005 Bonds and paying a portion of the costs associated with the issuance. For that purpose, the proceeds from the sale of the Series 2014 Bonds shall be allocated and deposited as provided in Section 6 of this Resolution.

Section 4. Terms and Provisions Applicable to the Series 2014 Bonds.

(a) **Form and Numbering.** The Series 2014 Bonds shall be issued, unless otherwise subsequently provided in the Sixth Supplemental Trust Agreement entered into pursuant to the Trust Agreement, only in the form of fully registered Bonds, substantially in the form set forth in Exhibit A to the Sixth Supplemental Trust Agreement with such changes as may be necessary to reflect the terms of the Series 2014 Bonds set forth in the Certificate of Award. The Series 2014 Bonds shall be fully registered and numbered as determined by the Fiscal Officer in such manner as to distinguish each Series 2014 Bond from each other Series 2014 Bond.

The Series 2014 Bonds shall be initially issued only to a Securities Depository to be held in a book entry system and: (i) the Series 2014 Bonds shall be registered in the name of the Securities Depository or its nominee, as registered owner, and immobilized in the custody of the Securities Depository; and (ii) the Series 2014 Bonds as such shall be transferable or exchangeable in accordance with Section 2.06 of the Trust Agreement, provided, however that so long as a book entry system is used for the Series 2014 Bonds, they may only be transferred to another Securities Depository or to another nominee of a Securities Depository without further action by the University pursuant to subparagraph (e)(iii) of this Section. Notwithstanding Section 2.06 of the Trust Agreement, the University may, and may require the Trustee to, transfer the Series 2014 Bonds from one Securities Depository to another Securities Depository at any time.

(b) Terms.

(i) Denomination and Dates. The Series 2014 Bonds shall be issued in the denomination of \$5,000 and any integral multiple of \$5,000, and shall be dated as of the Delivery Date or such other date as may be provided in the Certificate of Award. Each Series 2014 Bond shall have only one principal maturity date, except for interim certificates or receipts which may be issued pending preparation of definitive Bonds.

(ii) Interest. The Series 2014 Bonds shall bear interest from the later of (i) their date or (ii) the most recent date to which interest has been paid or provided for, payable on the Interest Payment Dates at the respective rates per annum set forth in the Certificate of Award.

(iii) Maturities. The Series 2014 Bonds shall mature on March 1 and/or September 1 in the years and in the principal amounts as provided in the Certificate of Award, with the initial maturity and final maturity as set forth in section (c) below.

(iv) Prior Redemption.

(A) The Series 2014 Bonds may be subject to redemption at the option of the University prior to their stated maturities on the redemption dates and at the redemption prices specified in the Certificate of Award. The Fiscal Officer may determine in the Certificate of Award that some or all of the Series 2014 Bonds are not to be callable prior to stated maturity. The Fiscal Officer further may determine in the Certificate of Award that a premium shall be payable to the bondholder upon early redemption of a Series 2014 Bond and that such premium may be calculated in a manner to make the bondholder whole for the loss of the investment or may be calculated as a percentage of the principal amount to be redeemed.

(B) The Series 2014 Bonds of one or more maturities may be subject to mandatory redemption pursuant to Mandatory Sinking Fund Requirements by the University at a redemption price equal to 100% of the principal amount redeemed, plus accrued interest to the date of

redemption, on September 1 in the years and in the principal amounts provided in the Certificate of Award.

(v) Construction Period. Due to the complexity of the Series 2014 University Facilities Project, including the necessity of staggering construction to accommodate housing requirements, it is reasonably expected that the Series 2014 University Facilities Project, which involves a substantial amount of construction expenditures, will take longer than three (3) years to complete. In connection therewith, the University shall obtain a certificate from a licensed architect or engineer.

(c) Maturities: Bond Service Charges. The first maturity or mandatory sinking fund payment and the final maturity of the Series 2014 Bonds shall not be later than the dates specified in the Certificate of Award. Principal shall be payable in each year from the first maturity or mandatory sinking fund payment year to the final maturity year either at stated maturity or pursuant to Mandatory Sinking Fund Requirements. The weighted average interest rate on all the Series 2014 Bonds shall not exceed 5% per annum. Annual Bond Service Charges on all the Series 2014 Bonds shall be in accordance with the Certificate of Award.

(d) Redemption Prior to Maturity.

(i) If fewer than all of the outstanding Series 2014 Bonds are called for optional redemption at one time, the Series 2014 Bonds to be called shall be designated by the Fiscal Officer in his sole discretion and in any manner the Fiscal Officer determines, without regard to the order of their maturities or their interest rates. If fewer than all of the outstanding Series 2014 Bonds of one maturity and interest rate are to be called for redemption, the selection of the Series 2014 Bonds, or portions of those Series 2014 Bonds (in integral multiples of \$5,000), of that maturity to be called for redemption shall be made in the manner provided in the Sixth Supplemental Trust Agreement. If optional redemption of any Series 2014 Bonds at a redemption price above 100% of the principal amount to be redeemed is to take place on any applicable mandatory sinking fund redemption date, the selection of the Series 2014 Bonds to be optionally redeemed shall be selected prior to the selection of the Series 2014 Bonds to be redeemed by mandatory sinking fund redemption.

(ii) Notice of call for redemption of Series 2014 Bonds, setting forth the information provided for in Section 3.03 of the Trust Agreement, shall be given by the Trustee on behalf of the University. Failure to receive notice by mailing, or any defect in that notice, as to any Series 2014 Bond shall not affect the validity of the proceedings for the redemption of any other Series 2014 Bond.

(e) Places and Manner of Payment and Paying Agents.

(i) The principal of and any redemption premium on Series 2014 Bonds shall be payable when due only to the registered owners, upon presentation and surrender of the Series 2014 Bonds at the principal corporate trust office of the Trustee.

(ii) Interest on any Series 2014 Bond due on each Interest Payment Date shall be payable by check or draft which the Trustee shall cause to be mailed on the Interest

Payment Date to the person who is the registered owner of the Bond (or one or more predecessor Bonds) at the close of business on the Regular Record Date applicable to that Interest Payment Date, at the address then appearing on the Register. If and to any extent, however, that the University shall make neither payment nor provision for payment of interest on any Series 2014 Bond on any Interest Payment Date, that interest shall cease to be payable to the person who was the registered owner of that Bond (or of one or more predecessor Bonds) as of the applicable Regular Record Date; when moneys become available for payment of that interest the Trustee shall, subject to Section 2.05 of the Trust Agreement, establish a Special Record Date for the payment of that interest which shall be not more than 15 or fewer than 10 days prior to the date of the proposed payment, and the Trustee shall cause notice of the proposed payment and of the Special Record Date to be mailed to the person who is the registered owner of that Bond on a date not fewer than 10 days prior to the Special Record Date, at the address as then appears on the Register, and thereafter that interest shall be payable to the person who is the registered owner of that Bond (or a predecessor Bond) at the close of business on the Special Record Date.

(iii) Notwithstanding any other provision of this Resolution or any provision of the General Bond Resolution, the Trust Agreement, the Sixth Supplemental Trust Agreement or any Series 2014 Bond to the contrary, with the written approval of the University, the Trustee may enter into an agreement with a Securities Depository, or the nominee of a Securities Depository that is the registered owner of a Series 2014 Bond in the custody of that Securities Depository providing for making all payments to that registered owner of principal of and interest and any premium on that Series 2014 Bond or any portion of that Series 2014 Bond (other than any payment of its entire unpaid principal amount) at a place and in a manner (including wire transfer of federal funds) other than as provided above in this Resolution, without prior presentation or surrender of the Series 2014 Bond, upon any conditions which shall be satisfactory to the Trustee and the University. That payment in any event shall be made to the person who is the registered owner of that Series 2014 Bond on the date that principal and premium is due, or, with respect to the payment of interest, as of the applicable Regular Record Date or Special Record Date or other date agreed upon, as the case may be. The Trustee will furnish a copy of each of those agreements, certified to be correct by an officer of the Trustee, to other authenticating agents and paying agents for Series 2014 Bonds, if any, and to the University. Any payment of principal, premium, or interest pursuant to such an agreement shall constitute payment thereof pursuant to, and for all purposes of, this Resolution and the Sixth Supplemental Trust Agreement.

(iv) Alternate Paying Agents may be designated in the Certificate of Award by the Fiscal Officer.

(f) Execution and Authentication. The Series 2014 Bonds shall be executed and authenticated in the manner provided in the Trust Agreement. Alternate Authenticating Agents may be designated by the Fiscal Officer in the Certificate of Award.

Section 5. Sale of Series 2014 Bonds.

- (a) General. The Fiscal Officer is authorized to determine:
- (i) that the Series 2014 Bonds shall be issued;
 - (ii) the Principal Amount of Series 2014 Bonds to be issued provided that the aggregate amount of Series 2014 Bonds shall not to exceed \$200,000,000;
 - (iii) the interest rates on the Series 2014 Bonds;
 - (iv) the amount of any original issue discount and/or premium on the Series 2014 Bonds;
 - (v) the maturities of the Series 2014 Bonds, as limited by Section 4(c) herein;
 - (vi) the optional and mandatory redemption dates, if any, and redemption prices for the Series 2014 Bonds; and
 - (vii) the purchase price for the Series 2014 Bonds.

The Series 2014 Bonds shall be sold by the Fiscal Officer to the Original Purchaser on such terms not inconsistent with this Resolution as are provided in the Certificate of Award and the Bond Purchase Agreement.

The Fiscal Officer is authorized and directed to execute the Certificate of Award and the Bond Purchase Agreement, in order to provide for the definitive terms and terms of sale of the Series 2014 Bonds as provided in this Resolution, and to award and provide for sale of the Series 2014 Bonds to the Original Purchaser. The Bond Purchase Agreement shall not be materially adverse to the University as shall be approved by the Fiscal Officer, his execution of the Bond Purchase Agreement to constitute conclusive approval of any such changes on behalf of the University. The Certificate of Award shall be incorporated in and form a part of the Sixth Supplemental Trust Agreement.

(b) Official Statement. The Fiscal Officer is authorized and directed, on behalf of the University, and in his official capacity, to prepare or cause to be prepared, a preliminary official statement relating to the original issuance of the Series 2014 Bonds; to determine, and to certify or otherwise represent, when such preliminary official statement is “deemed final” for purposes of Securities and Exchange Commission Rule 15c2-12(b)(1); and to use and distribute, or authorize the use and distribution of such preliminary official statement in connection with the original issuance of the Series 2014 Bonds until an official statement is prepared. All actions previously taken by the Fiscal Officer in this regard relating to a preliminary official statement are hereby approved, ratified and confirmed.

The Fiscal Officer is further authorized and directed, on behalf of the University, and in his official capacity, to prepare or cause to be prepared an official statement, and any necessary supplements thereto, relating to the original issuance of the Series 2014 Bonds; to determine, and to certify or otherwise represent, when such official statement is a final official statement for

purposes of Securities and Exchange Commission Rule 15c2-12(b)(3) and (4); to use and distribute, or authorize the use and distribution of such official statement, and any supplements thereto, in connection with the sale of the Series 2014 Bonds; and to sign and deliver the official statement.

The Fiscal Officer is further authorized and directed, on behalf of the University, and in his official capacity, to sign and deliver such certificates in connection with the accuracy of the preliminary official and the final official statements and any supplements thereto as may, in his judgment, be necessary or appropriate.

(c) Further Authorization. The Fiscal Officer is further authorized and directed, on behalf of the University, and in his official capacity, to sign and deliver on the Issuance Date, such other certificates and documents as may be reasonably necessary in the opinion of Bond Counsel to complete the sale of the Series 2014 Bonds. The General Counsel in her official capacity is hereby authorized and directed to sign and deliver on the Issuance Date a legal opinion in form and substance acceptable to Bond Counsel.

Section 6. Allocation of Proceeds of Series 2014 Bonds.

(a) Allocation. All of the proceeds from the sale of the Series 2014 Bonds shall be received and receipted for by the Fiscal Officer or by his authorized representative for that purpose, and shall be allocated, deposited and credited as follows:

(i) To the Bond Service Account in the Bond Service Fund, any portion of the proceeds representing accrued or capitalized interest, if any;

(ii) To the 2014 Costs of Issuance Fund an amount, to be determined by the Fiscal Officer, to pay the costs of issuance of the Series 2014 Bonds; and

(iii) To the appropriate account created in the Escrow Deposit Agreement (the "Refunding Account") to be applied to the refunding of the Series 2005 Bonds; and

(iv) To the 2014 Project Fund, hereby established, the balance of the proceeds, to be applied to pay costs of the 2014 University Facilities Project as determined by the Fiscal Officer and as described in the preambles.

(b) 2014 Project Fund.

(i) The 2014 Project Fund shall be held by the University in a separate deposit account or accounts (except when invested as provided below) set up in a bank or banks that are members of the Federal Deposit Insurance Corporation, and used to pay costs of the Series 2014 University Facilities Project that constitute "costs of facilities" as defined in the Act (the "Project Costs").

(ii) The Fiscal Officer shall apply the 2014 Project Fund pursuant to the provisions of this Section 6 to the payment of the Project Costs, including, without limitation, the reimbursement of the University for moneys heretofore advanced to pay Project Costs in anticipation of the issuance of the Series 2014 Bonds.

(iii) Moneys to the credit of the 2014 Project Fund, pending their application as above set forth, shall be subject to a lien and charge in favor of the holders of the Series 2014 Bonds, and the University covenants that it will not cause or permit to be paid from the 2014 Project Fund any moneys except in compliance with the provisions of this Resolution, the Trust Agreement and the Sixth Supplemental Trust Agreement.

(iv) Moneys on deposit in the 2014 Project Fund may be invested by or at the direction of the Fiscal Officer in Eligible Investments (as defined in the Sixth Supplemental Trust Agreement) maturing or redeemable at the option of the holder prior to the time needed for the purposes thereof. The investments and the proceeds of their sale shall constitute part of the 2014 Project Fund, and earnings from any of those investments shall be credited to the 2014 Project Fund. The investments may be sold, exchanged or collected from time to time by or at the direction of the Fiscal Officer.

(v) Any balance remaining in the 2014 Project Fund after the Fiscal Officer has certified to the Trustee that payment of Project Costs has been accomplished or provided for to the satisfaction of the University shall be deposited in the Bond Service Account and used for payment of principal on the Series 2014 Bonds, or expended for costs of University Facilities with the approval of the Board if that payment or expenditure shall not, in the opinion of Bond Counsel to the University, adversely affect the exclusion of interest on the Series 2014 Bonds from gross income for federal income tax purposes.

(c) 2014 Costs of Issuance Fund.

(i) The 2014 Costs of Issuance Fund shall be held by the University in a separate deposit account or accounts set up in a bank or banks that are members of the Federal Deposit Insurance Corporation, and used to pay costs of issuance of the Series 2014 Bonds that constitute “costs of facilities” as defined in the Act (the “Costs of Issuance”).

(ii) The Fiscal Officer shall apply the 2014 Costs of Issuance Fund pursuant to the provisions of this Section 6 to the payment of the Costs of Issuance, including, without limitation, the reimbursement of the University for moneys heretofore advanced to pay Costs of Issuance in anticipation of the issuance of the Series 2014 Bonds.

(iii) Moneys to the credit of the 2014 Costs of Issuance Fund, pending their application as above set forth, shall be subject to a lien and charge in favor of the holders of the Series 2014 Bonds, and the University covenants that it will not cause or permit to be paid from the 2014 Costs of Issuance Fund any moneys except in compliance with the provisions of this Resolution, the Trust Agreement and the Sixth Supplemental Trust Agreement.

(iv) Moneys on deposit in the 2014 Costs of Issuance Fund may be invested by or at the direction of the Fiscal Officer in Eligible Investments (as defined in the Sixth Supplemental Trust Agreement) maturing or redeemable at the option of the holder prior to the time needed for the purposes thereof. The investments and the proceeds of their

sale shall constitute part of the 2014 Costs of Issuance Fund, and earnings from any of those investments shall be credited to the 2014 Costs of Issuance Fund. The investments may be sold, exchanged or collected from time to time by or at the direction of the Fiscal Officer.

(v) Any balance remaining in the 2014 Costs of Issuance Fund after the Fiscal Officer has certified to the Trustee that payment of Costs of Issuance has been accomplished or provided for to the satisfaction of the University shall be deposited in the Bond Service Account and used for payment of principal on the Series 2014 Bonds, or expended for costs of University Facilities with the approval of the Board if that payment or expenditure shall not, in the opinion of Bond Counsel to the University, adversely affect the exclusion of interest on the Series 2014 Bonds from gross income for federal income tax purposes.

(d) Refunding Account.

(i) The Refunding Account shall be held by the Escrow Trustee and invested and used as set forth in the Escrow Deposit Agreement.

Section 7. Tax Covenants; Rebate Fund.

(a) Covenants. The University hereby covenants that:

(i) It will restrict the use of the proceeds of the Series 2014 Bonds in such manner and to such extent, if any, as may be necessary so that the Series 2014 Bonds will not constitute arbitrage bonds under Section 148 of the Code. The Fiscal Officer, or any other officer of the University having responsibility for the issuance of the Series 2014 Bonds, alone or in conjunction with any other officer or employee of or any consultant to the University, shall give an appropriate certificate of the University, for inclusion in the transcript of proceedings for the Series 2014 Bonds, setting forth the reasonable expectations of the University regarding the amount and use of all the proceeds of the Series 2014 Bonds, the facts, circumstances and estimates on which they are based, and other facts and circumstances relevant to the tax treatment of the interest on the Series 2014 Bonds.

(ii) It (a) will take or cause to be taken such actions that may be required of it for the Series 2014 Bonds to be and remain Tax-Exempt Bonds at the time of their delivery to the Original Purchaser, and (b) will not take or authorize to be taken any actions that would adversely affect that status under the Code, and that it, or persons acting for it, will, among other acts of compliance, (1) apply the proceeds of the Series 2014 Bonds to the governmental purpose of the borrowing, (2) restrict the yield on investment property acquired with those proceeds, (3) make timely rebate payments to the federal government, (4) maintain books and records and make calculations and reports, and (5) refrain from certain uses of those proceeds, all in such manner and to the extent necessary to assure such exclusion of that interest under the Code. The Fiscal Officer and other appropriate officers are authorized and directed to take any and all actions, make calculations and rebate payments to the federal government, and make or

give reports and certifications, as may be appropriate to assure such exclusion of that interest.

(b) **Rebate Fund.** There is hereby created the Series 2014 Bonds Rebate Fund (the Rebate Fund), to be in the custody of the Trustee, which shall be continuously invested in Eligible Investments by the Trustee at the oral direction (confirmed in writing) of the Fiscal Officer. The Rebate Fund shall be held, administered and disposed of in accordance with the provisions of the Sixth Supplemental Trust Agreement. Amounts credited to the Rebate Fund are not General Receipts and shall be free and clear of any lien under the Sixth Supplemental Trust Agreement or under the Trust Agreement.

Section 8. Credit Enhancement; Escrow Deposit Agreement; Other Agreements. If he determines it to be in the best interest of the University in order to achieve maximum cost savings on the Series 2014 Bonds, the Fiscal Officer may obtain credit enhancement for all or any portion of the Series 2014 Bonds.

The Fiscal Officer is authorized to enter into such agreements and to make such changes to the Sixth Supplemental Trust Agreement and the Series 2014 Bond form as may be required in connection with such credit enhancement. The Fiscal Officer is further authorized to enter into such agreements and execute such certificates as may be required in connection with the issuance, sale and delivery of the Series 2014 Bonds.

The Fiscal Officer is authorized and directed to execute and deliver to the Escrow Trustee, in the name of and on behalf of the University, an Escrow Deposit Agreement in connection with the refunding of the Series 2005 Bonds.

Section 9. Sixth Supplemental Trust Agreement. The Chairman of the Board or the President of the University, and the Fiscal Officer, or any one or more of them, are authorized and directed to execute and deliver to the Trustee, in the name of and on behalf of the University, and the Secretary to the Board is authorized and directed to attest, a Sixth Supplemental Trust Agreement pursuant to the Trust Agreement and in connection with the issuance of the Series 2014 Bonds.

Section 10. Open Meeting. It is found and determined that all formal actions of this Board concerning and relating to the adoption of this Resolution were taken in an open meeting of this Board, and that all deliberations of this Board and of any of its committees that resulted in those formal actions were taken in meetings open to the public, in full compliance with applicable legal requirements including Section 121.22 of the Revised Code.

BOARD OF TRUSTEES OF MIAMI
UNIVERSITY

By: 
Theodore O. Pickerill II
Secretary to the Board of Trustees

Adopted: February 7, 2014

I attest that this is a true and accurate copy of the original resolution R-2014-36 passed by the Miami University Board of Trustees on February 7, 2014 and remains in effect.

Theodore O. Pickerill II
Secretary to the Board of Trustees

February 11, 2014

*Approved by the Board of Trustees
February 7, 2014*

T. O. Pickerill II
Secretary to the Board of Trustees